

At a Glance

The Cadenza Acoustic Banner is a budget friendly option within the J&C Joel variable acoustic range. Deploying a single layer of Bonded Wool Serge it achieves a Class B acoustic absorption rating according to EN ISO 11654:1997.

The Cadenza can offer an absorbent area of upto 40m². With 5m as the maximum width, and 9m as the maximum drop. Custom sizes are available on request.

Works with Bonded Wool Serge*, available in 1,130gsm, 1000gsm, or 840gsm to achieve different acoustic requirements. Standard fabric colour is black, with a range 10 colours available on 1,000gsm, custom colours available subject to MoQ. ***100% recycled wool product.** Other fabrics are available for acoustic or decorative purposes.

Standard operating speed is around 140mm/s which enables a 5m tall banner to deploy in 35s.

Designed and Manufactured in the UK.

Acoustic Absorption

A single layer of fabric is positioned at a predefined distance from a wall to reduce reverberation time.

The fabric to wall distances have been tested at 100 & 350mm centres. Tests were conducted using a 3rd party and the full reports are available on request.

Fabric	Fabric-Wall Distance mm	Acoustic Absorption Co-efficient					
		125Hz	250Hz	500Hz	1000Hz	2000Hz	4000Hz
Bonded Wool Serge 1130 gsm	100	0.10	0.40	0.75	0.90	0.80	0.95
	150	0.26	0.90	0.98	0.81	0.77	0.79
	350	0.25	0.65	0.75	0.85	0.85	1.00
Bonded Wool Serge 840 gsm	100	0.10	0.40	0.75	0.85	0.75	0.85
	350	0.25	0.65	0.70	0.80	0.80	0.95
Bonded Coloured Wool Serge 1000 gsm	150	0.22	0.91	0.98	0.88	0.75	0.85

Fabric Positions

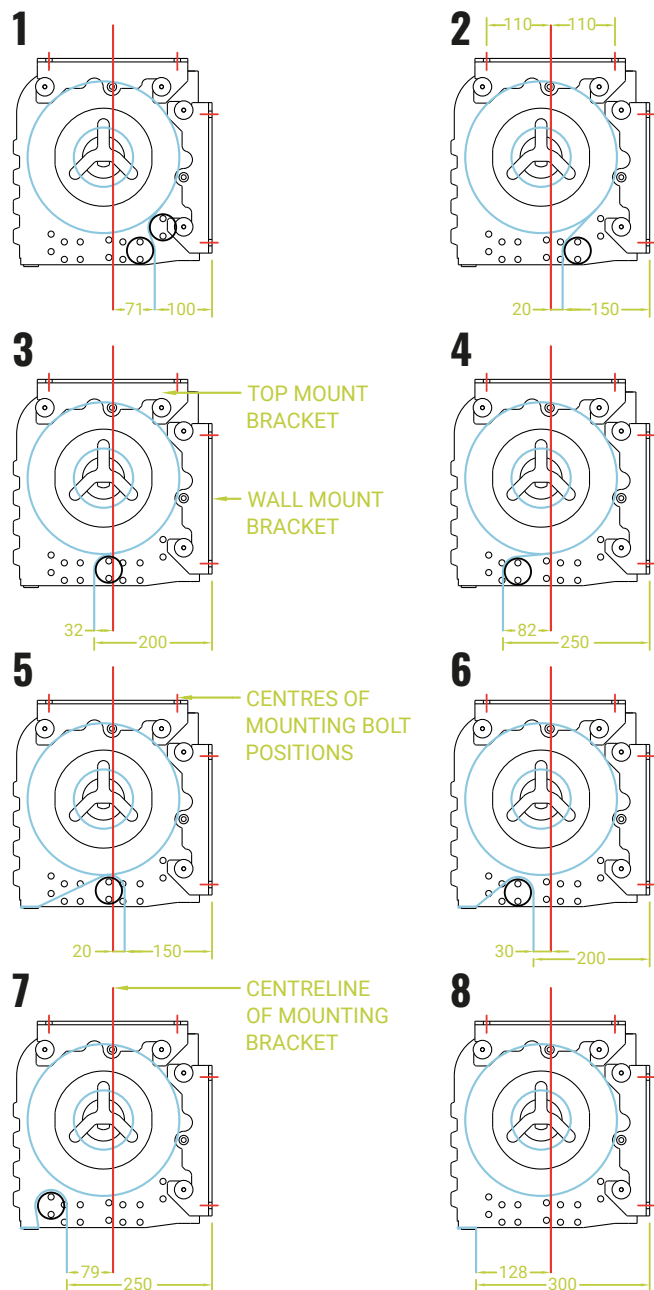

Features

- Tubular motor (typically Becker)
- End of travel limit switches
- Standard power requirement of 230v 13A power supply per banner location.

Fabric Positions

- The banners have multiple in-built fabric positions to enable flexibility of positioning, these are shown.
- Please note that positions 5 - 8 are not applicable to a Cadenza as these are only used for a second layer of fabric, as on the Legato or Duet models.

Installation

- Mounting brackets provide a simple wall or ceiling fix. The same part is used for both scenarios. Once the brackets are fixed, the banner slots into place and is fixed with a bolt.
- Three different brackets are available to further adjust the different gaps between the fabric and the wall.
- The dimensions shown use the standard bracket. The mid bracket would increase all dimensions by 20mm, and the XL bracket would increase by 100mm.
- For top mounting, J&C Joel recommend to only use the XL bracket.
- J&C Joel strongly advise that adjacent mechanisms are installed no less than 60mm from each other, less can make servicing very difficult. This means that the fabric drops on adjacent banners is spaced 160mm
- J&C Joel can provide full installation services or supply drawings to aid your installation

Banner Spacing

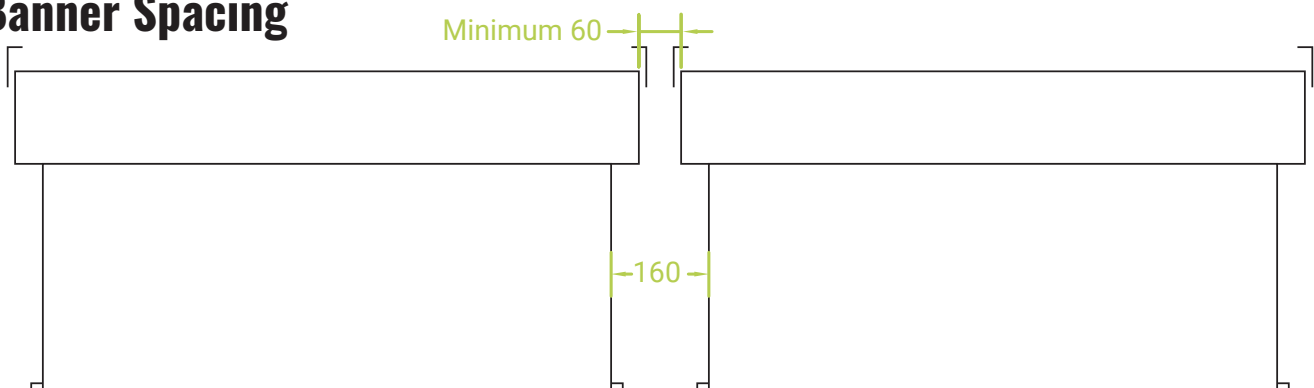

Wired Control Schematic

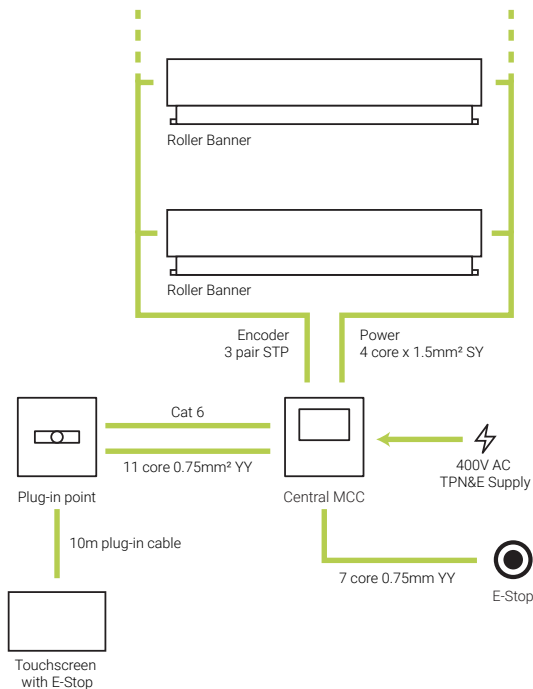

Wireless Control Schematic

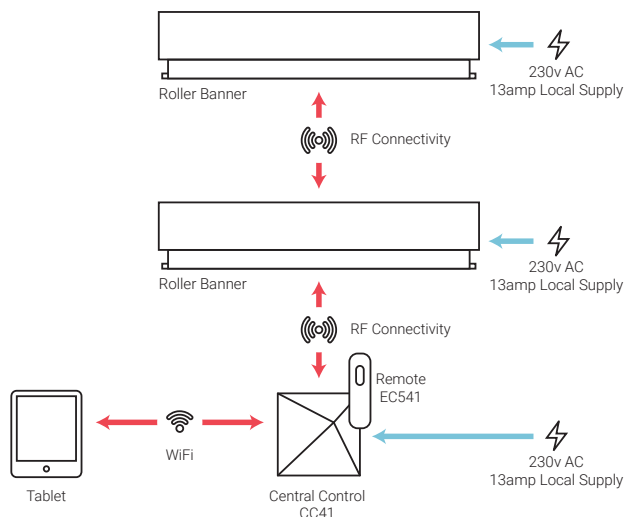

Motor Wiring Diagram

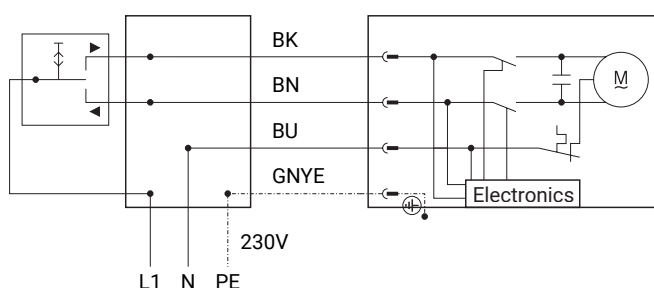

Wired Control

- J&C Joel can provide a customised control system to operate banners individually, as groups or with predefined presets
- The wired control is recommended for mid-large scale venues, or where encoders are required.
- Typically, this requires power and data fed to each banner from a central MCC
- Can be linked to a building management system
- Control system compliant with BS EN 17206:2020
- Each system is custom so please get in touch to discuss your requirements

Wireless Control

- Uses the motor manufacturer's propriety software, allowing control from a mobile device
- The wireless control is more suitable to smaller venues or installations
- Can be integrated into a building management system (BMS).
- Control via radio frequency, with the motors providing positional feedback to the control and signal amplification
- Application allows multiple pre-set positions for banners based on percentage of deployment.

Supply Only

- J&C Joel can provide the banner units without a control, enabling integration with an alternative control system.
- The typical motor wiring schematic is shown to the left. This can change, please confirm with J&C Joel before finalising your control system.
- J&C Joel offer a slimline incremental encoder as standard as this does not extend past the width of the banner. Typically; BEGE MIG NOVA+, impulse count 1024, AB/-A-B/90 Degrees, HTL / TTL, 10-24 VDC / 5 VDC
- Absolute encoders can also be used on request.