

**Oxford Humanities**  
**Operation & Maintenance Manual**  

---

**TRACK & DRAPE SYSTEMS**

Document No. : 4334-15-OM-0001  
Revision : B  
Date of Issue : 28/10/2025  
Project Code : 4334

**J&C Joel** 

## Contents

1. Document Control.....	3
1.1. Identification .....	3
1.2. Document History .....	3
1.3. Contact Details .....	3
1.4. Warranty .....	4
1.5. Copyright .....	4
2. How To Use This Manual .....	5
3. General.....	6
3.1. List of Drawings .....	6
4. Track & Drapery .....	7
4.1. 250 Seat Theatre.....	7
4.2. Black Box .....	8
4.3. Rehearsal Space.....	9
5. Maintenance .....	10
5.1. ML02 Inspection Sheet .....	10
5.2. ML01 Check Sheet.....	11
6. Referenced Drawings.....	12
7. Wool Serge 565 Datapack .....	19
8. Coloured Wool Serge Datapack .....	46

# 1. Document Control

## 1.1. Identification

Client: Laing O'Rourke

Project Name: Oxford Humanities

J&C Joel Project Reference: 4334

Document Name: Track & Drape Systems – Operation & Maintenance Manual

Document Reference: 4334-15-OM-0001

## 1.2. Document History

Rev	Date	Description	Author	Checked
A	13/08/2025	First Issue	JC	SS
B	28/10/2025	Updated as per consultant comments	JC	SS

## 1.3. Contact Details

### J&C Joel Ltd

Corporation Mill  
Corporation Street  
Halifax  
HX6 2QQ  
United Kingdom

T: +44 (0) 1422 833835  
E: UKprojects@jcjoel.com

### J&C Joel Middle East

Warehouse 12, 598-706,  
Dubai Investment Park 1,  
PO Box 23295  
Dubai  
United Arab Emirates

T: +971 (0) 4 884 7801  
E: InternationalProjects@jcjoel.com

## 1.4. Warranty

Limited warranty is valid for twelve (12) months from the date of practical completion and handover to the client or clients representative (whichever occurs first.)

1. The warranty shall be limited to the free supply of replacement materials and workmanship for the faulty materials or workmanship and shall not cover other damage or defects how so ever caused.
2. It shall be the client's responsibility to notify J&C Joel Ltd for any defects in the machinery and the warranty shall be void if repairs or other works were carried out by third parties.
3. This warranty shall only apply to the areas where J&C Joel Ltd have been applied and completed the works.
4. The supply of replacement materials and workmanship under this warranty shall in no event exceed the quantity specified and supplied and shall only be applied to proven defective areas by checking and tests conducted under the control of the owner, the consultant or its representative and J&C Joel Ltd or its representatives.
5. This warrantee shall be interpreted according to the laws of the United Kingdom.

## 1.5. Copyright

This document contains material that is proprietary to J&C Joel Ltd. This information is provided on the understanding that it is used solely for the purpose of information, installing and maintaining the equipment described, and that it will not be revealed to third parties or otherwise disposed of without the prior written consent of J&C Joel Ltd.

Copyright for all design, software, electronic circuits, drawings and the text of this manual remains with J&C Joel Ltd. This publication or parts thereof may not be reproduced in any form, by any method, for any purpose. Further copies may be obtained from J&C Joel Ltd. on request.

© 2025 J&C Joel Ltd.

## 2. How To Use This Manual

Read the instructions carefully before use and follow them accordingly. Keep this document safe for future reference. Non-observance of these instructions may lead to hazardous situations and / or malfunctions or to failure of the equipment, resulting in damage or injury.

The user is advised not to operate or undertake any work on the system without first reading and understanding the contents of this manual.

All maintenance should be carried out strictly in accordance with the instructions contained in this and the manufacturer's reference manuals attached and undertaken by suitably trained and qualified personnel.

This manual describes the J&C Joel supplied track and drape systems at the Oxford Humanities building. This information is pertinent to all spaces where the tracks and drapes are installed. Servicing or repairs of main fault conditions is not covered; in such cases please contact J&C Joel immediately.

This document is intended to provide the user with sufficient information to allow maintenance of the equipment described.

If in doubt about anything contained in this manual please contact the Projects Department at J&C Joel Ltd. T: +44 (0)1422 833835 – E: [ukprojects@jcjoel.com](mailto:ukprojects@jcjoel.com)

### 3. General

Multiple track and drapery systems have been installed by J&C Joel throughout the Schwarzman Centre.

In the 250 Seat Theatre there is an upstage track attached to the upstage fixed bar. There are two tracks adjacent to the downstage fixed bar, these are for the false proscenium, with part of the border tied to the downstage fixed bar. At B1 level there are two sets of tracks & drapes on either side of the stage, one to close the wings and one to continue the false proscenium line down from overhead. The drapery runs to the floor in all scenarios, except for the false proscenium header attached to the downstage fixed bar. All drapery in this venue is J&C Joel Black Wool Serge 565 gsm, and all tracks are Triple E 2-Way.

In the Black Box, four Triple E 2-Way tracks are installed on under the inside edge of the gantry. These are RAL matched to the steelwork. Suspended from these are ten sections of J&C Joel Black Wool Serge 565 gsm drapes, these are intended to be used in a modular fashion; added to the venue when required or removed entirely and stored in supplied bags.

In the Rehearsal Space, a full perimeter Triple E 2-Way track is installed at high level, RAL matched to the room's metalwork. J&C Joel Coloured "Original Grey" Wool Serge 500 gsm drapes are hung from this track, stopping 300mm from the floor for ventilation purposes.

In the Ensemble Room, a single Triple E 2-Way track is installed in front of the window. A bi-parting J&C Joel Coloured Wool Serge 500 gsm drape is hung, this is dyed a custom colour.

All drapes are inherently fire retardant (IFR) to BS5867 Part 2 Type B, NFPA 701, IMO and AS1530.2/3. This means that the fibres are flame retardant for life and if wet, would not need to be re-flameproofed. Therefore, the cloth will withstand wet cleaning but we would advise and suggest professional dry cleaning only, using the correct chemical process. Drapery Datapacks can be found at the end of this document.

#### 3.1. List of Drawings

DRAWING NO.	TITLE
UOONHB-JCJ-T2-ZZ-DR-OT-150002	250 Seat Theatre - Masking Track and Drape System Upstage - GA Short Section
UOONHB-JCJ-BB-BM-DR-OT-200001	Black Box - Perimeter Masking Track - GA Plan
UOONHB-JCJ-BB-ZZ-DR-OT-200002	Black Box - Perimeter Masking Track - GA Section
UOONHB-JCJ-RS-ZZ-DR-OT-240001	Rehearsal Room - Perimeter Masking Track - GA Plan
UOONHB-JCJ-RS-ZZ-DR-OT-240002	Rehearsal Room - Perimeter Masking Track - Section & Details
UOONHB-JCJ-XX-ZZ-DR-OT-260001	Ensemble Room - Track & Acoustic Curtain - GA Plan

## 4. Track & Drapery

Please note the tracks are only designed for the supplied curtains. No other curtains should be hung from the drapes. Similarly the tracks are not for rigging and no other loads should be hung from them.

### 4.1. 250 Seat Theatre

Track fitted to the upstage bar.



False proscenium, hung from the downstage fixed bar.



## 4.2. Black Box

The Black Box venue, four perimeter tracks mounted under the inside edge of the gantry, highlighted below in the green boxes;

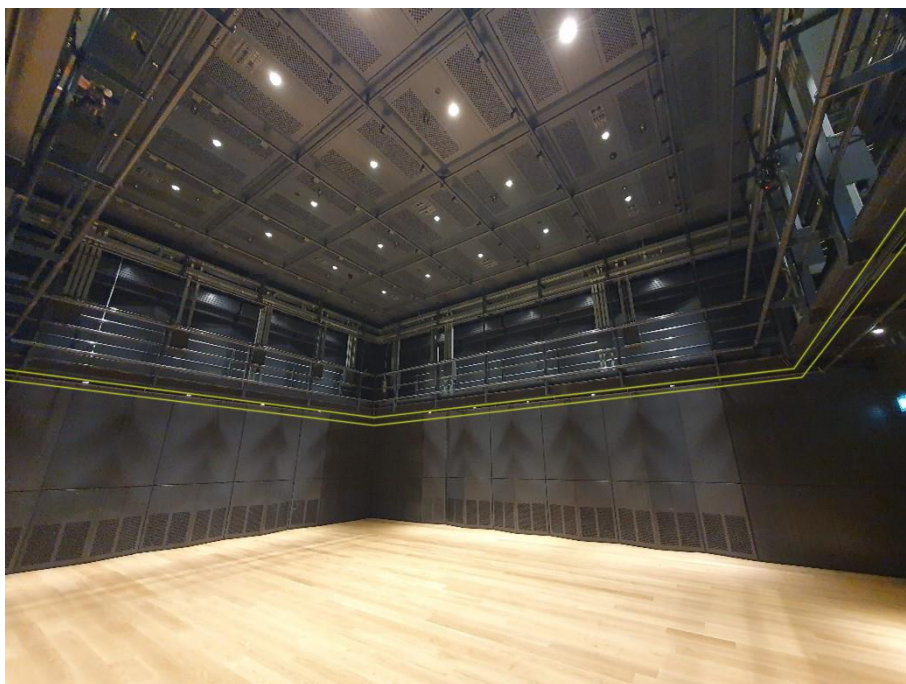

### 4.3. Rehearsal Space

A full perimeter track & drapery system.





## 5.2. ML01 Check Sheet

### Track & Drape Systems

		Pass	Fail	Rectified	N/A
<b>1</b>	<b>Appearance</b>				
1.1	Check equipment is neat and tidy	<input type="checkbox"/>	<input type="checkbox"/>	<input type="checkbox"/>	<input type="checkbox"/>
1.2	Check equipment is clean	<input type="checkbox"/>	<input type="checkbox"/>	<input type="checkbox"/>	<input type="checkbox"/>
<b>2</b>	<b>General</b>				
2.1	Check equipment for signs of liquid damage	<input type="checkbox"/>	<input type="checkbox"/>	<input type="checkbox"/>	<input type="checkbox"/>
2.2	Check equipment for signs of any other damage	<input type="checkbox"/>	<input type="checkbox"/>	<input type="checkbox"/>	<input type="checkbox"/>
<b>3</b>	<b>Mechanical</b>				
3.1	Check all fixings (nuts, bolts and washers) are secure	<input type="checkbox"/>	<input type="checkbox"/>	<input type="checkbox"/>	<input type="checkbox"/>
3.2	Check the wall behind the brackets for signs of damage or wear	<input type="checkbox"/>	<input type="checkbox"/>	<input type="checkbox"/>	<input type="checkbox"/>
3.3	Check all fixings and or brackets are tightened	<input type="checkbox"/>	<input type="checkbox"/>	<input type="checkbox"/>	<input type="checkbox"/>
3.4	Check all runners for signs of wear or damage	<input type="checkbox"/>	<input type="checkbox"/>	<input type="checkbox"/>	<input type="checkbox"/>
3.5	Check track splice plates for tightness	<input type="checkbox"/>	<input type="checkbox"/>	<input type="checkbox"/>	<input type="checkbox"/>
3.6	Check all track runners move smoothly over full travel	<input type="checkbox"/>	<input type="checkbox"/>	<input type="checkbox"/>	<input type="checkbox"/>
3.7	Inspect the track for signs of wear or damage	<input type="checkbox"/>	<input type="checkbox"/>	<input type="checkbox"/>	<input type="checkbox"/>
3.8	Clean the track	<input type="checkbox"/>	<input type="checkbox"/>	<input type="checkbox"/>	<input type="checkbox"/>
3.9	Inspect curtain fabric for tears, stains or deterioration	<input type="checkbox"/>	<input type="checkbox"/>	<input type="checkbox"/>	<input type="checkbox"/>
3.10	Check all snap hooks are present and undamaged	<input type="checkbox"/>	<input type="checkbox"/>	<input type="checkbox"/>	<input type="checkbox"/>
3.11	Check curtain stacks without snagging	<input type="checkbox"/>	<input type="checkbox"/>	<input type="checkbox"/>	<input type="checkbox"/>
3.12	Check fabric joins and webbing for sign of damage	<input type="checkbox"/>	<input type="checkbox"/>	<input type="checkbox"/>	<input type="checkbox"/>
3.13	Keep the area under the curtain clean always	<input type="checkbox"/>	<input type="checkbox"/>	<input type="checkbox"/>	<input type="checkbox"/>

## 6. Referenced Drawings

Drawings are shown overleaf.

# Upstage Masking Short Section View - 150002

This drawing is the property of J&C Joel Limited and associated companies. It must not be copied or the contents divulged to any third party without prior written consent.

REVISIONS			
REV.	BY	DESCRIPTION	DATE
P01	SH	FIRST ISSUE	30/05/2024
P02	SH	REVISED	01/08/2024
C01	SH	CONSTRUCTION ISSUE	15/04/2025
C02	SH	FOR RECORD	05/08/2025

**Notes:**

To be read in conjunction with;  
 UOONHB-JCJ-T2-ZZ-DR-OT-150001  
 UOONHB-JCJ-T2-ZZ-DR-OT-150003  
 UOONHB-JCJ-T2-ZZ-DR-OT-150004  
 UOONHB-SFD-T2-ZZ-DR-S-000003\_Ver2

For details of the Fixed Rigging Bars;  
 UOONHB-JCJ-T2-ZZ-DR-OT-140007  
 UOONHB-JCJ-T2-ZZ-DR-OT-140008  
 UOONHB-JCJ-T2-ZZ-DR-OT-140009  
 UOONHB-JCJ-T2-ZZ-DR-OT-140010  
 UOONHB-JCJ-T2-ZZ-DR-OT-140011

Equipments set out in room as per ;  
 UOONHB-CBL-T2-BM-DR-OT-1121\_P01

Triple-E 2 Way Tracks - Straight runs;  
 - PPC RAL9005 when above level of B1M.  
 - PPC RAL7030 when below level of B1M.

Runners at 300mm Centers - Black Plastic

Snap Hook Used to be self-colour Chrome

Bolts and other Fixings to be self-colour BZP.

**Status:**

A -  B -  C -

All dimensions in mm unless otherwise stated. Do not scale.

DRAWN:	SH	DATE:	05/08/2025
CHECKED:	JC	DATE:	05/08/2025
APPROVED:	OS	DATE:	05/08/2025
SCALE:	ON SHEET	PAPER SIZE:	A1

**J&C Joel**  
 Inspiration in every performance

PROJECT	4334 - Oxford Humanities
JCJ NO.	4334-GA-15-0002
DRG NO.	UOONHB-JCJ-T2-ZZ-DR-OT-150002
TITLE	250 Seat Theatre Masking Track and Drape System Upstage - GA Short Section
PURPOSE	A5 - Accepted as Suitable for Record
REV	C02

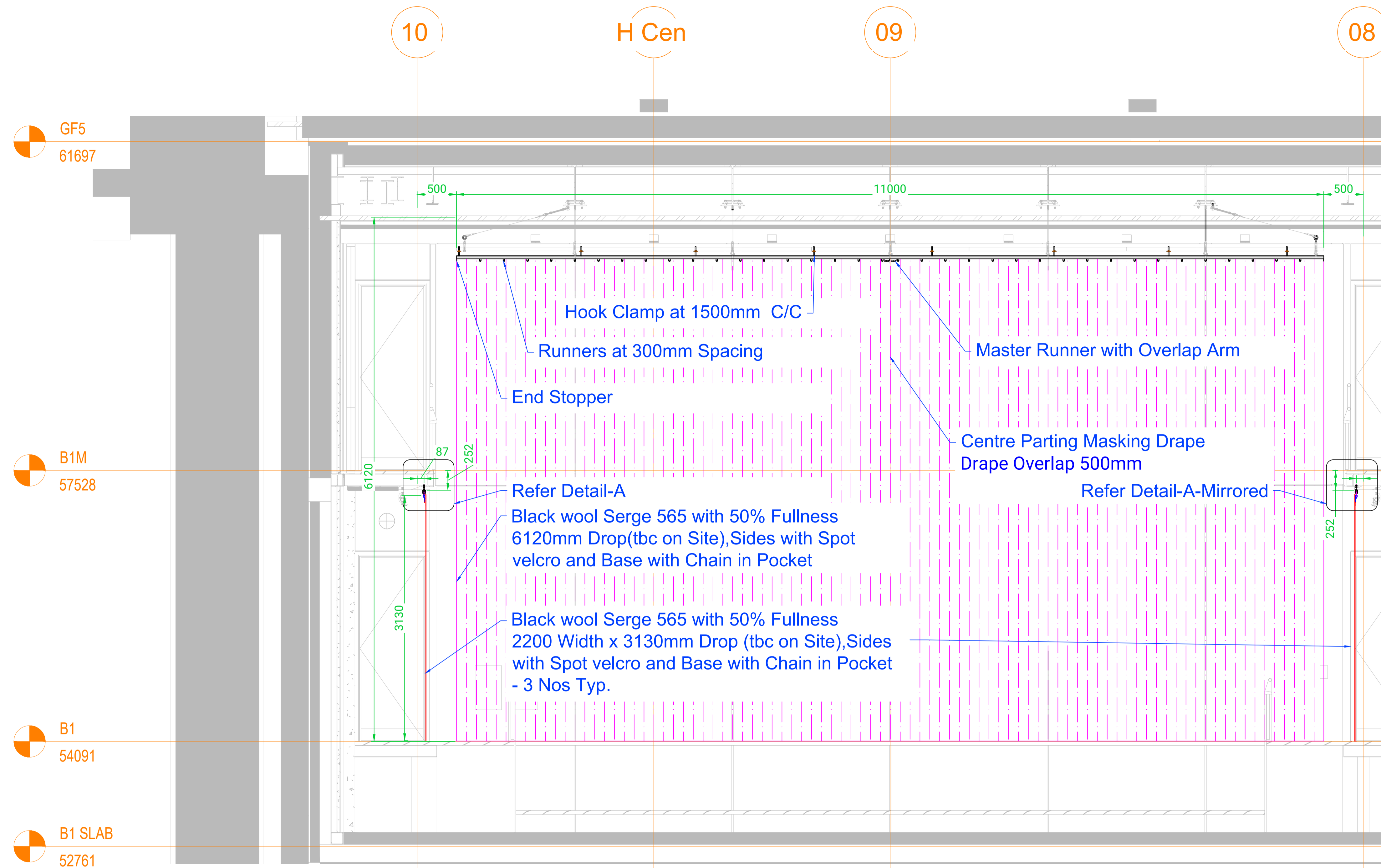

GF5  
61697

B1M  
57528

B1  
54091

B1 SLAB  
52761

Scale 1:30

Reference Drawing:UOONHB-HAL-T2-ZZ-DR-A-006812\_DRAFT

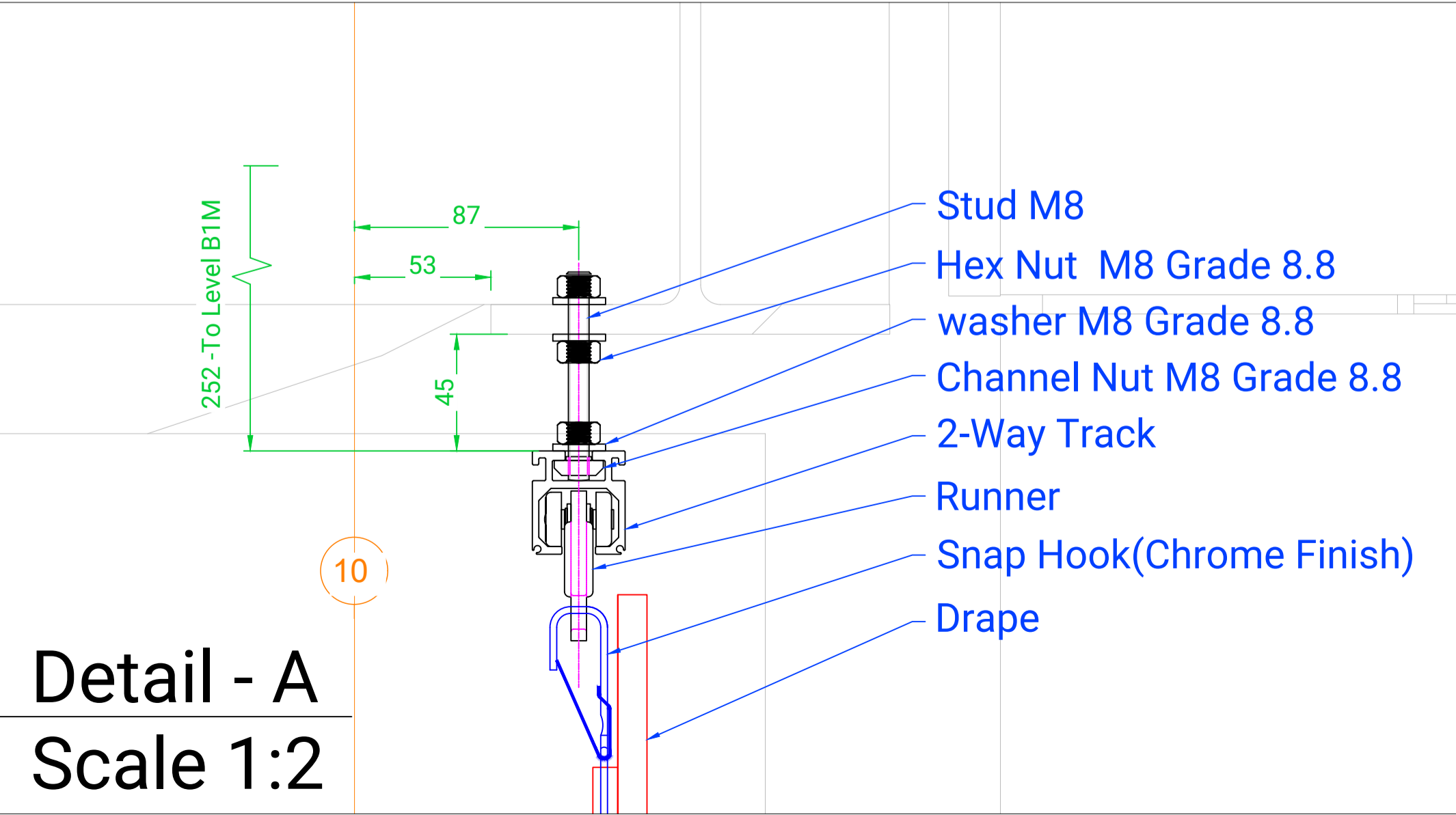

Detail - A  
Scale 1:2

REVISIONS			
REV.	BY	DESCRIPTION	DATE
P01	SH	FIRST ISSUE	22/05/2024
C01	SH	RESPONSE TO CONSULTANT COMMENTS	20/06/2024
C02	SH	REVISED	09/08/2024
C03	SH	For Record	28/04/2025

Notes:

Drawing to be read in conjunction with;  
UOONHB-JCJ-BB-ZZ-DR-OT-200002

Base drawing from;  
UOONHB-HAL-BB-BM-DR-A-005002  
UOONHB-CBL-BB-B1-DR-OT-001130

Triple-E 2 Way Tracks - 4 Straight runs - PPC RAL7024.

Each panel of drape 3000mm Width  
Runners at 300mm Centers - Black Plastic

Golf Bag Hook Used to be self-colour Chrome

Bolts and other Fixings to be self-colour BZP.

All dimensions in mm unless otherwise stated. Do not scale.

DRAWN:	SH	DATE:	28/04/2025
CHECKED:	JC	DATE:	28/04/2025
APPROVED:	OS	DATE:	28/04/2025
SCALE:	ON SHEET	PAPER SIZE:	A1

**J&C Joel**  
Inspiration in every performance

PROJECT	4334 - OXFORD HUMANITIES
DRAWING NO.	UOONHB-JCJ-BB-BM-DR-OT-200001

TITLE	Black Box Perimeter Masking Track GA Plan
PURPOSE	A5 - Accepted as Suitable for Record

REV C03

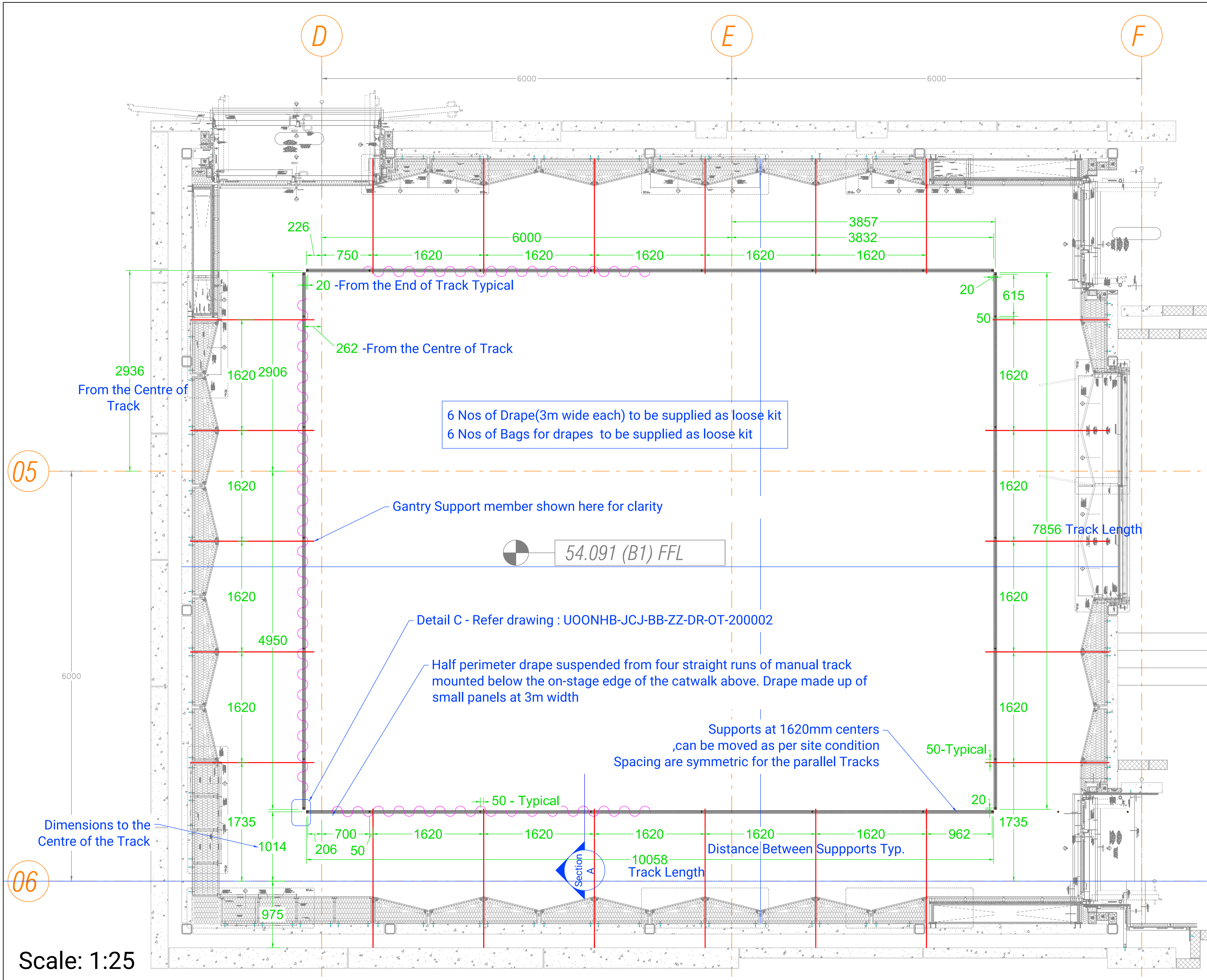

Scale: 1:25

REVISIONS			
REV.	BY	DESCRIPTION	DATE
P01	SH	FIRST ISSUE	22/05/2024
C01	SH	RESPONSE TO CONSULTANT COMMENTS	19/06/2024
C02	SH	RESPONSE TO CONSULTANT COMMENTS	05/09/2024
C03	SH	For Record	28/04/2025

Notes:

Drawing to be read in conjunction with;  
UOONHB-JCJ-BB-BM-DR-OT-200001

Base drawing from  
UOONHB-JAJ-BB-ZZ-DR-O-00518  
UOONHB-CBL-BB-B1-DR-OT-001130

Triple-E 2 Way Tracks - 4 Staright runs - PPC  
RAL7024.

Each panel of drape 3000mm Width  
Runners at 300mm Centers - Black Plastic

Golf Bag Hook Used to be self-colour Chrome

Bolts and other Fixings to be self-colour BZP.

All dimensions in mm unless otherwise stated. Do not scale.

DRAWN:	SH	DATE:	28/04/2025
CHECKED:	JC	DATE:	28/04/2025
APPROVED:	OS	DATE:	28/04/2025
SCALE:	ON SHEET	PAPER SIZE:	A1

**J&C Joel**  
Inspiration in every performance

PROJECT	4334 - OXFORD HUMANITIES
DRAWING NO.	UOONHB-JCJ-BB-ZZ-DR-OT-200002

TITLE  
Black Box  
Perimeter Masking Track  
GA Section

PURPOSE  
A5 - Accepted as  
Suitable for Record

REV C03

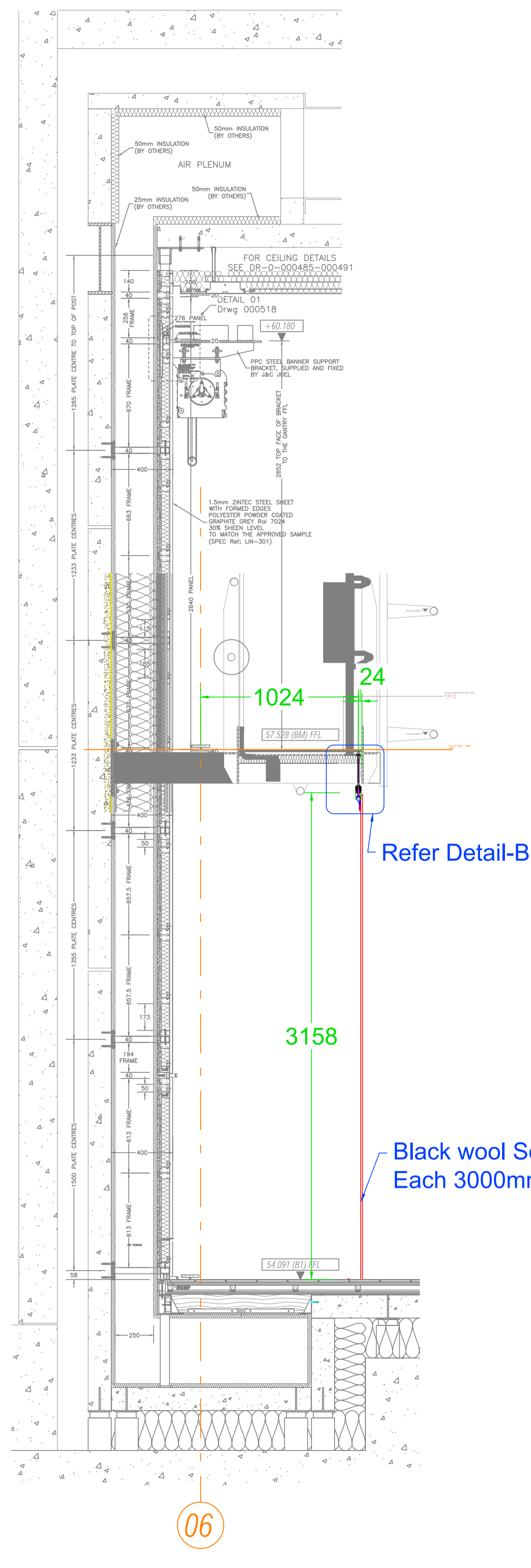

Section A  
Scale: 1:20

57.528 (BM) FFL

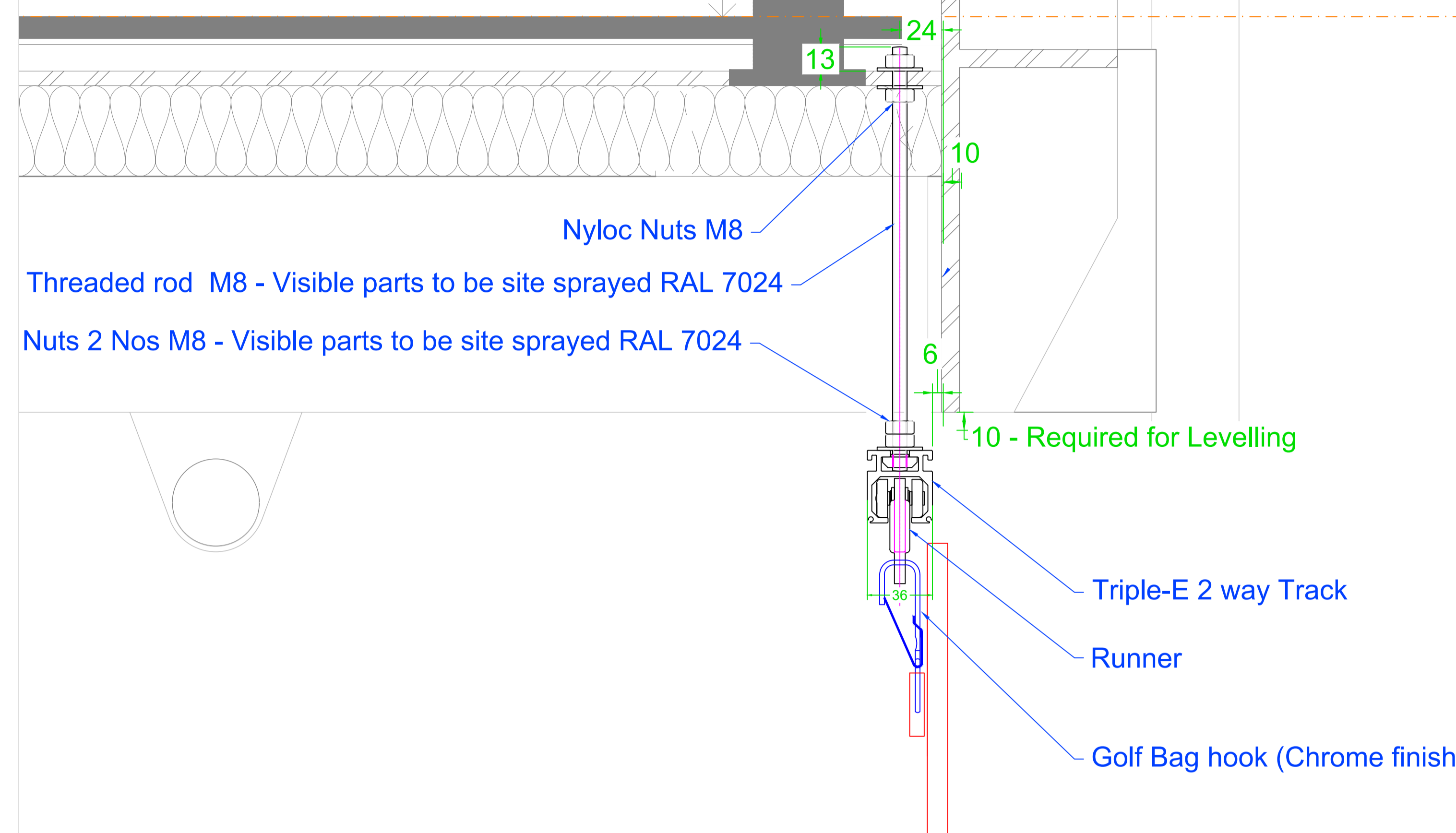

Scale: 1:2 Detail-B

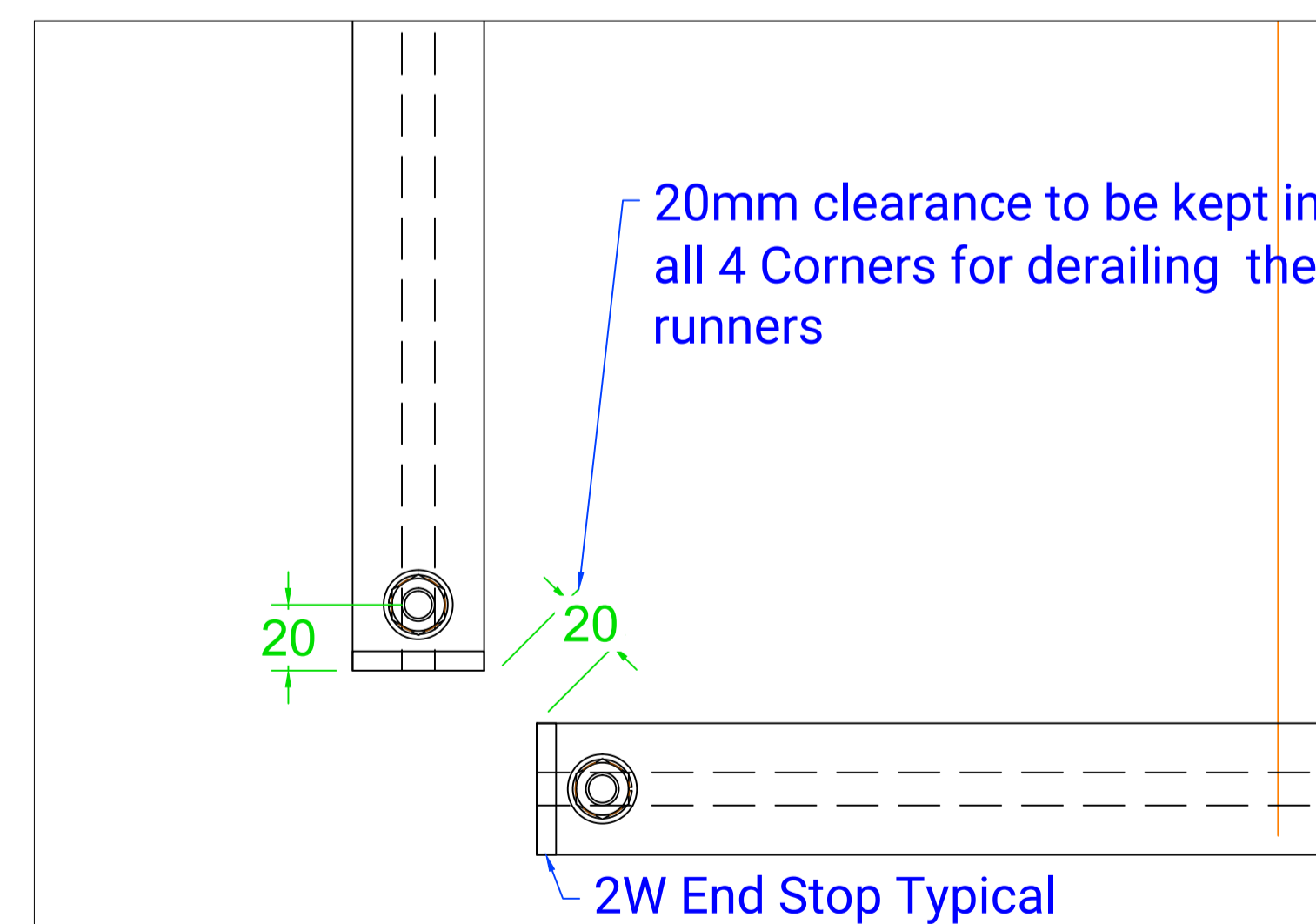

Refer to drawing  
UOONHB-JCJ-BB-BM-DR-OT-200001  
for location of details

Scale: 1:2 Detail-C





2W End Stop

Black wool Serge with 50% Fullness  
Each 3000mm wide & 3158mm Drop

REVISIONS			
REV.	BY	DESCRIPTION	DATE
P01	JR	FIRST ISSUE	26/04/2024
P02	JR	REVISED AS PER COMMENTS	15/05/2024
C01	JR	RESPONSE TO CONSULTANT'S COMMENTS	21/05/2025
C02	SH	For Record	28/04/2025

Notes:

- Perimeter Track Arrangement based on the As-Built Halfen Channel Locations
- Drawing to be read in conjunction with; UOONHB-JCJ-RS-ZZ-DR-OT-240002
- Tracks to be painted RAL9002  
Other components to be RAL9002 unless otherwise stated
- Bolts and other Fixings to be self-colour BZP
- Track runners to be manufacturer's standard black plastic
- Track Loadings:  
88kg UDL @ 1m Support  
34kg UDL @ 2m Support

-  Track Beam Suspension Hangers
-  Track Halfen Channel Suspension Hangers

All dimensions in mm unless otherwise stated. Do not scale.

DRAWN:	SH	DATE:	28/04/2025
CHECKED:	JC	DATE:	28/04/2025
APPROVED:	OS	DATE:	28/04/2025
SCALE:	ON SHEET	PAPER SIZE:	A1



PROJECT	4334 - OXFORD HUMANITIES
DRAWING NO.	UOONHB-JCJ-RS-ZZ-DR-OT-240001

TITLE	Rehearsal Room Perimeter Masking Track GA Plan
PURPOSE	A5 - Accepted as Suitable for Record

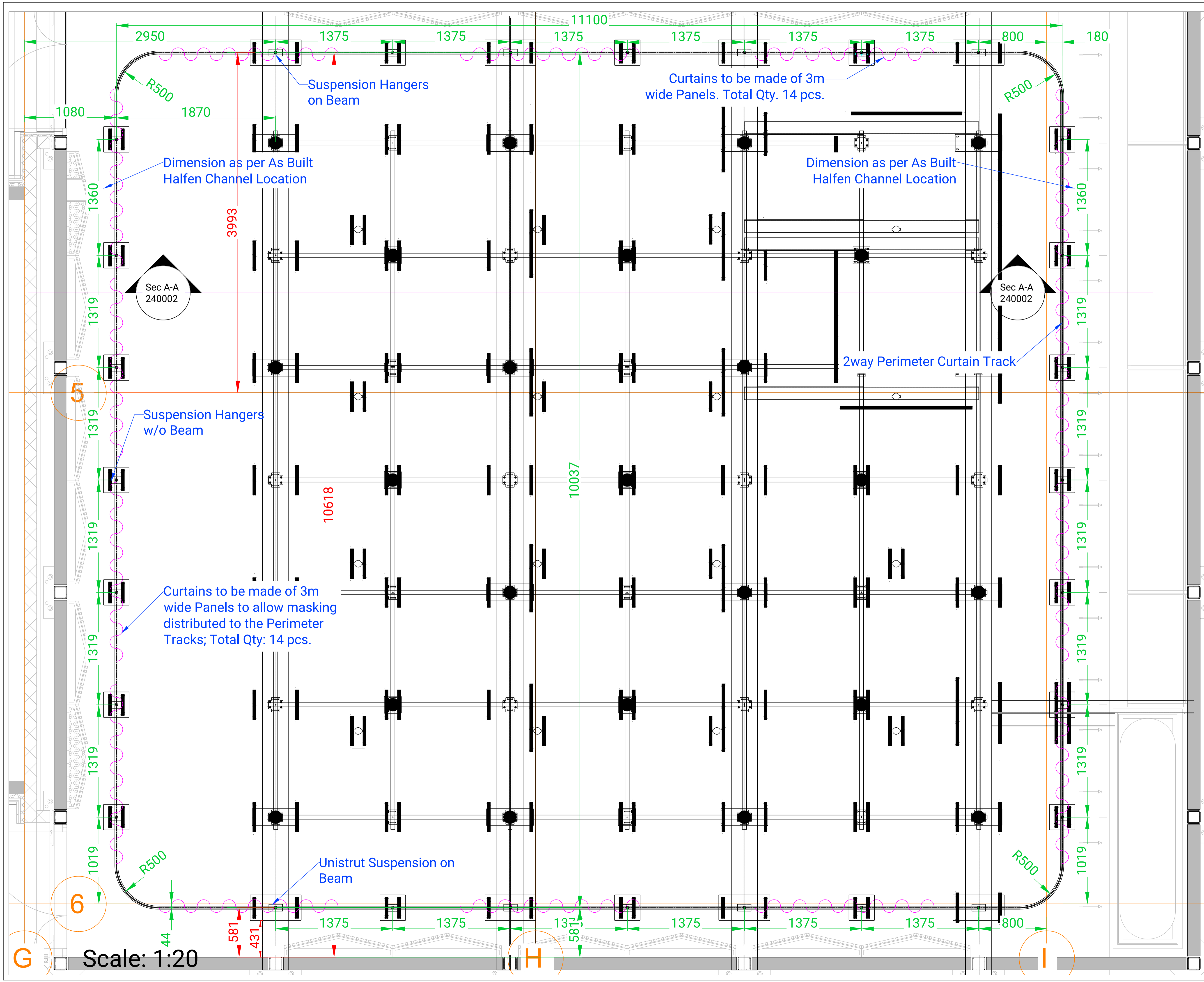

Scale: 1:20

REVISIONS			
REV.	BY	DESCRIPTION	DATE
P01	JR	FIRST ISSUE	26/04/2024
P02	JR	REVISED AS PER COMMENTS	15/05/2024
C01	JR	RESPONSE TO CONSULTANT'S COMMENTS	21/05/2024
C02	SH	For Record	28/04/2025

**Notes:**

Perimeter Track Arrangement based on the As-Built Halfen Channel Locations

Drawing to be read in conjunction with; UOONHB-JCJ-RS-ZZ-DR-OT-240002

Tracks to be painted RAL9002  
Other components to be RAL9002 unless otherwise stated

Bolts and other Fixings to be self-colour BZP

Track runners to be manufacturer's standard black plastic

Track Loadings:  
88kg UDL @ 1m Support  
34kg UDL @ 2m Support

All dimensions in mm unless otherwise stated. Do not scale.

DRAWN:	SH	DATE:	28/04/2025
CHECKED:	JC	DATE:	28/04/2025
APPROVED:	OS	DATE:	28/04/2025
SCALE:	ON SHEET	PAPER SIZE:	A1

**J&C Joel**  
Inspiration in every performance

PROJECT	4334 - OXFORD HUMANITIES
DRAWING NO.	UOONHB-JCJ-RS-ZZ-DR-OT-240002

TITLE	Rehearsal Room Perimeter Masking Track Section & Details
PURPOSE	A5 - Accepted as Suitable for Record

REV	DATE	DESCRIPTION
C02		

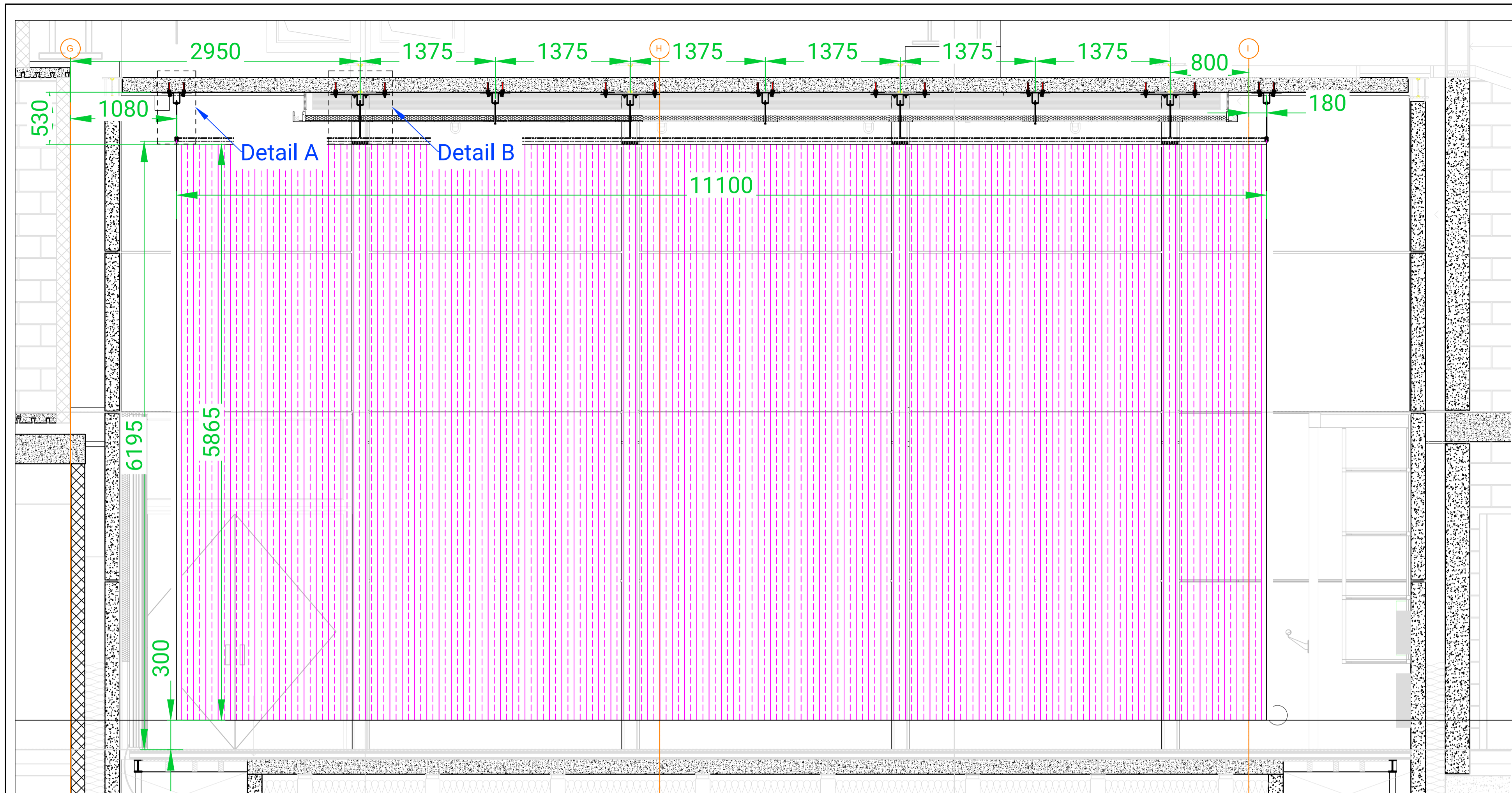

Section A-A  
1:30

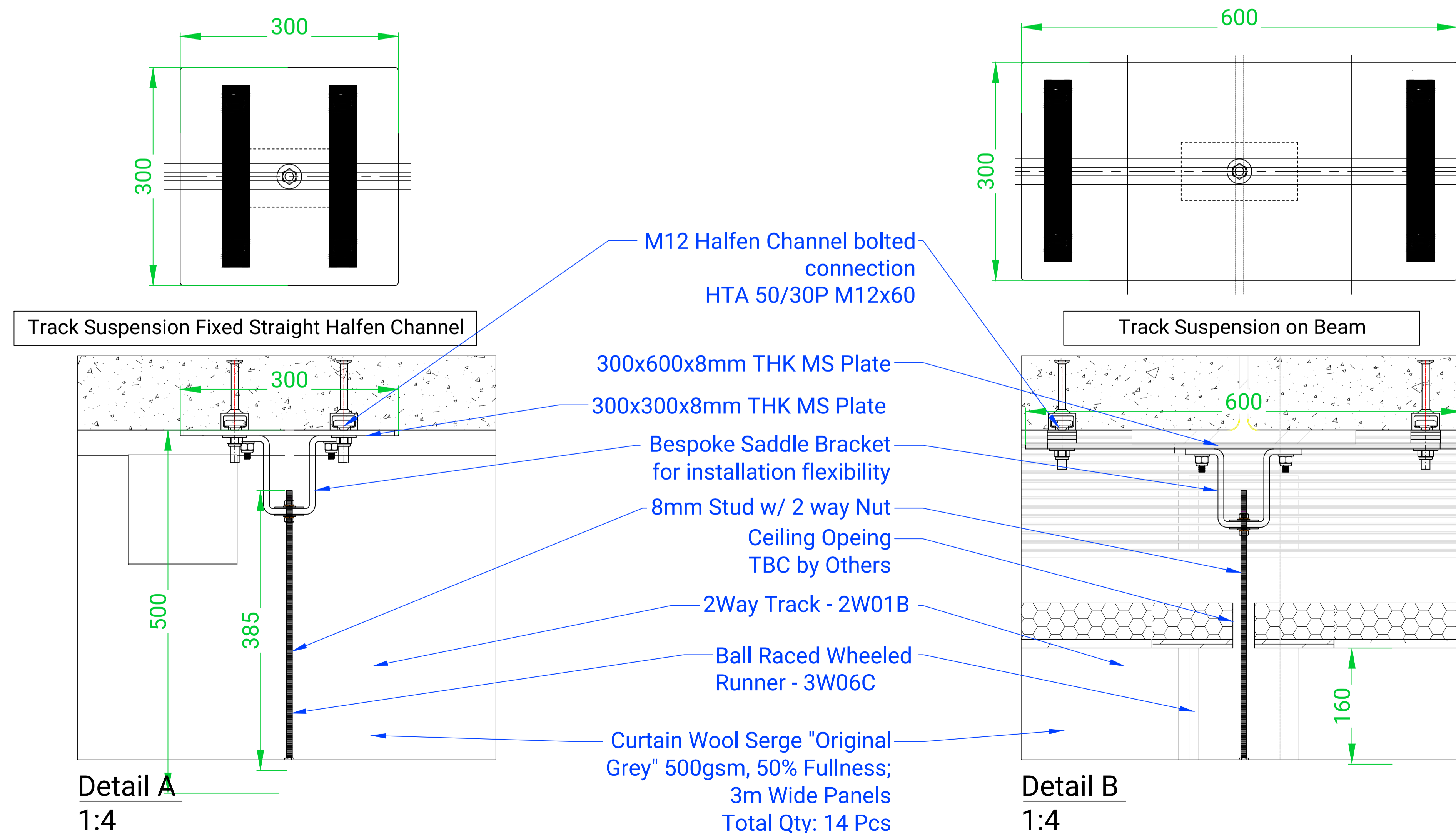

Detail A  
1:4

Detail B  
1:4

REVISIONS			
REV.	BY	DESCRIPTION	DATE
P01	SH	FIRST ISSUE	28/10/2024
C01	SH	Revised as per consultant comments	16/04/2025
C02	SH	For Record	28/04/2025

Notes:

To be read in conjunction with:  
 UOONHB-HAL-ZZ-00-DR-A-005380  
 UOONHB-HAL-ZZ-00-DR-A-006664  
 UOONHB-PUR-ZZ-00-DR-A-432455

- Triple-E 2 Way Tracks - Straight run;  
- PPC RAL9016
- Runners at 300mm Centers - Black Plastic
- Coutersunk Screws at 300mm Centers
- Snap Hook Used to be self-colour Chrome
- Any Fixings to be self-colour BZP.

Status:

A -  B -  C -

All dimensions in mm unless otherwise stated. Do not scale.

DRAWN: SH DATE: 28/04/2025

CHECKED: JC DATE: 28/04/2025

APPROVED: OS DATE: 28/04/2025

SCALE: ON SHEET PAPER SIZE: A1

**J&C Joel**  
 Inspiration in every performance

PROJECT 4334 Oxford Humanities

JCJ NO. 4334-GA-26-0001

Client Dwg no. UOONHB-JCJ-XX-ZZ-DR-0T-260001

TITLE Ensemble Room  
 Tracks & Acoustic Curtain  
 GA Plan

PURPOSE A5 - Accepted as  
 Suitable for Record

REV C02

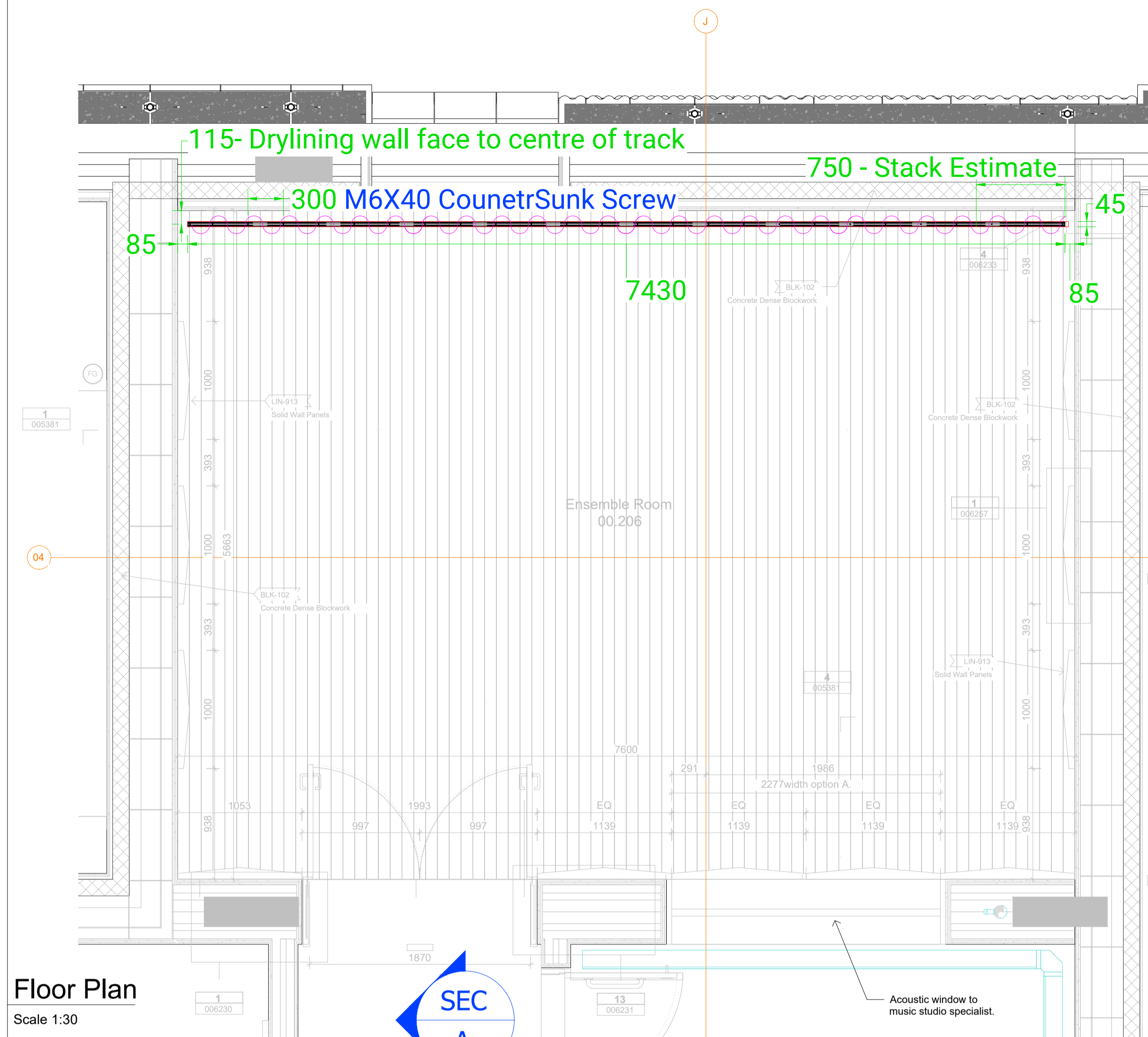

Floor Plan  
 Scale 1:30

SEC  
 A

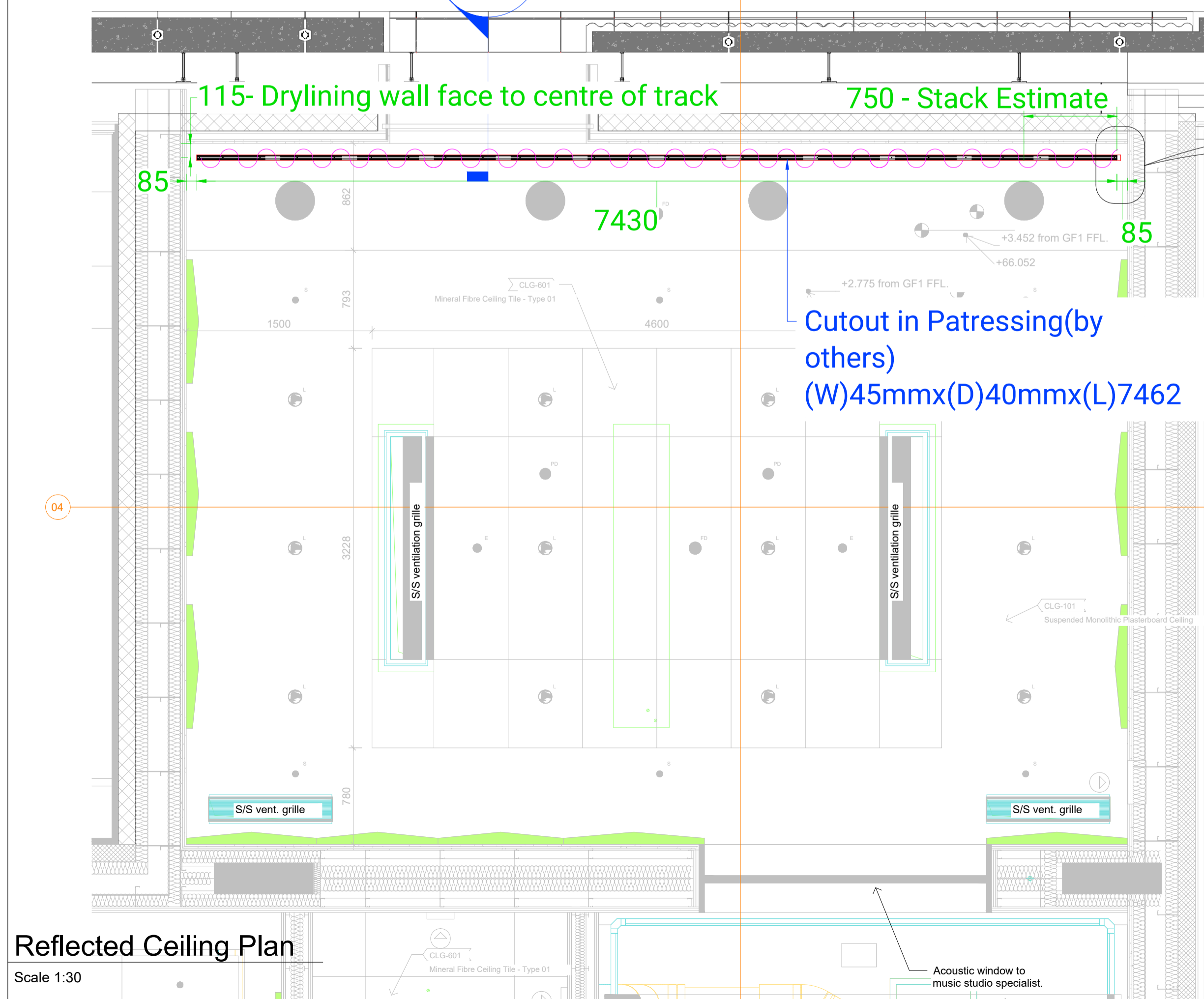

Reflected Ceiling Plan  
 Scale 1:30

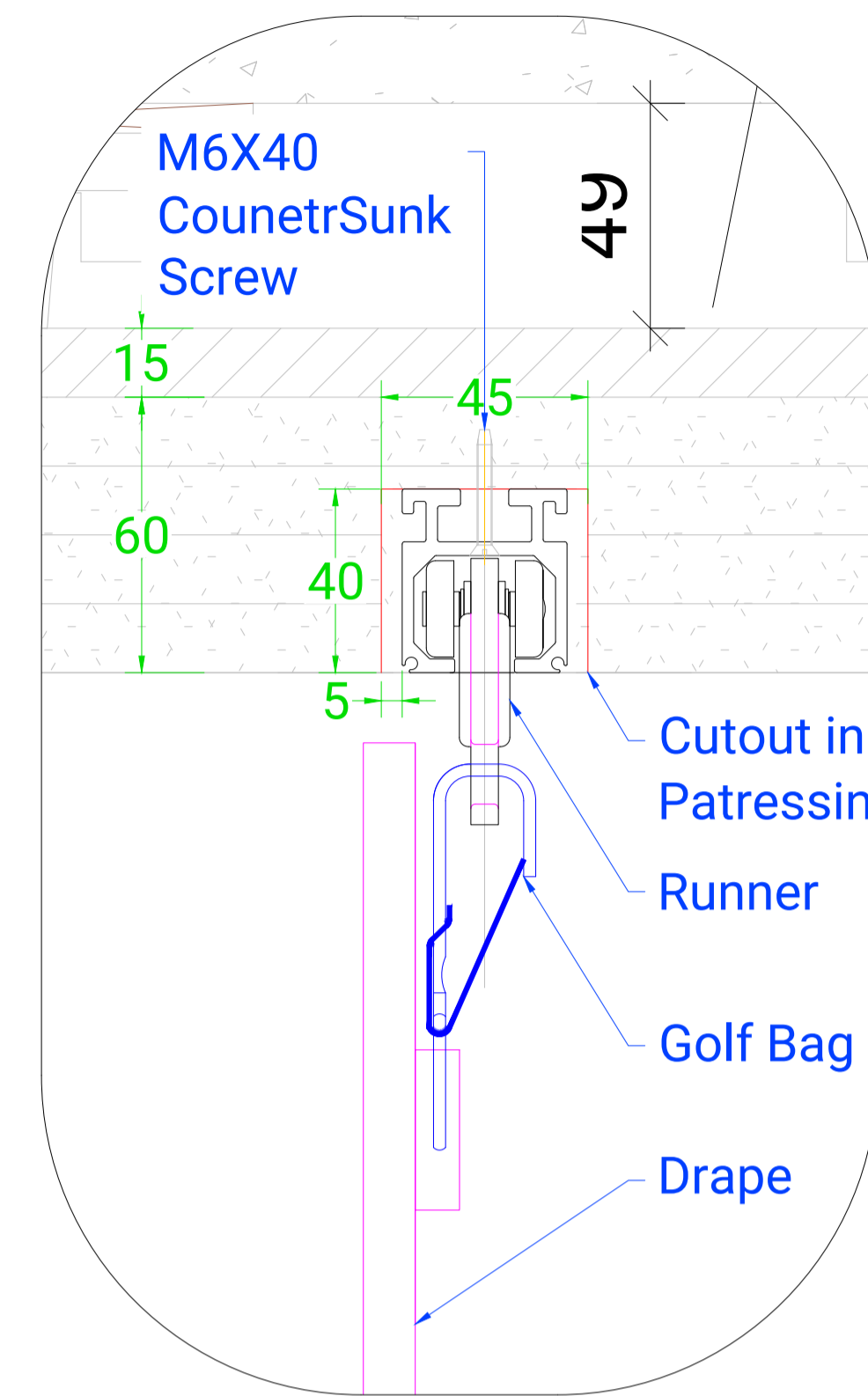

Detail - B  
 Scale NTS

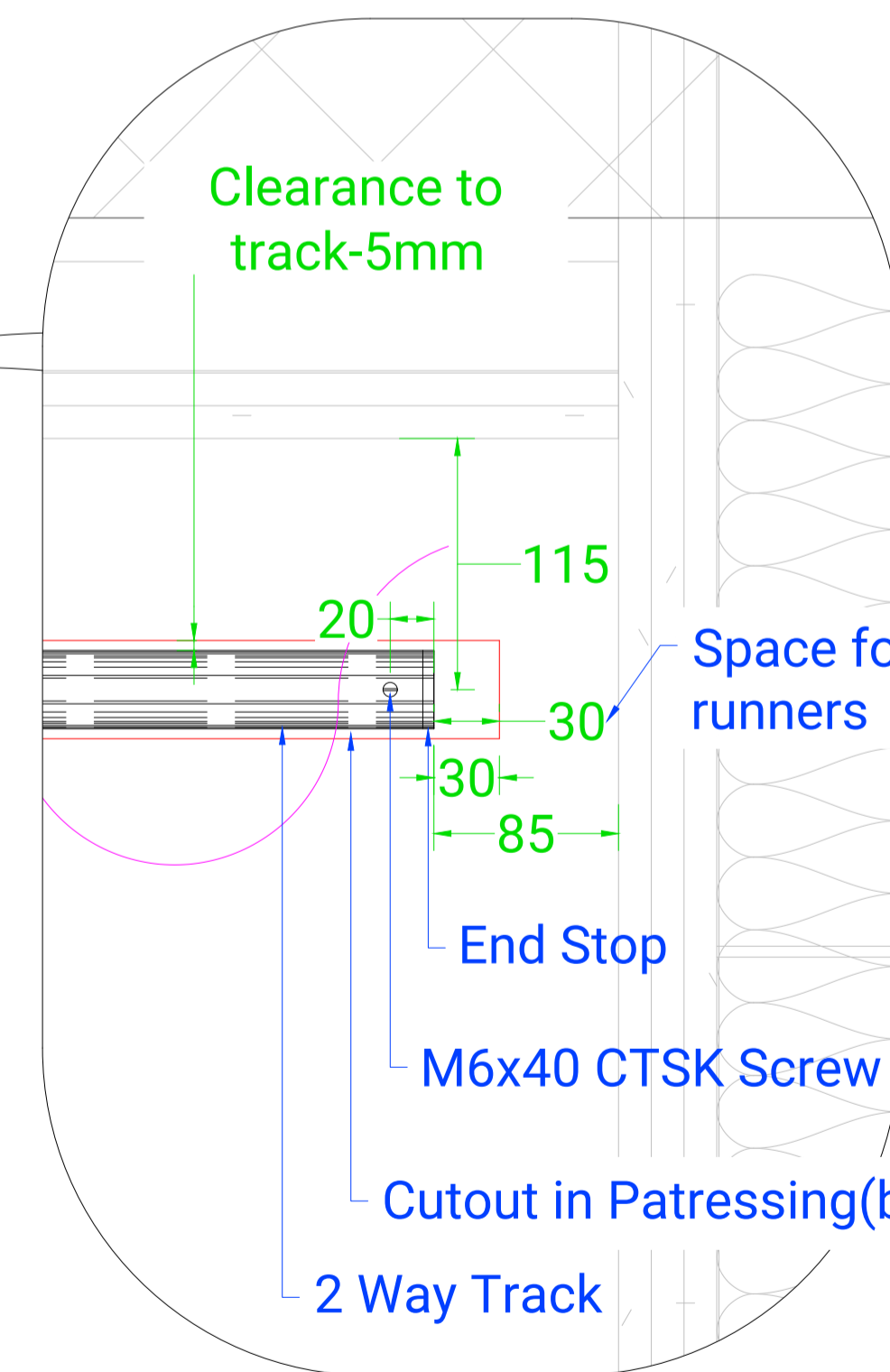

Detail - C  
 Scale NTS

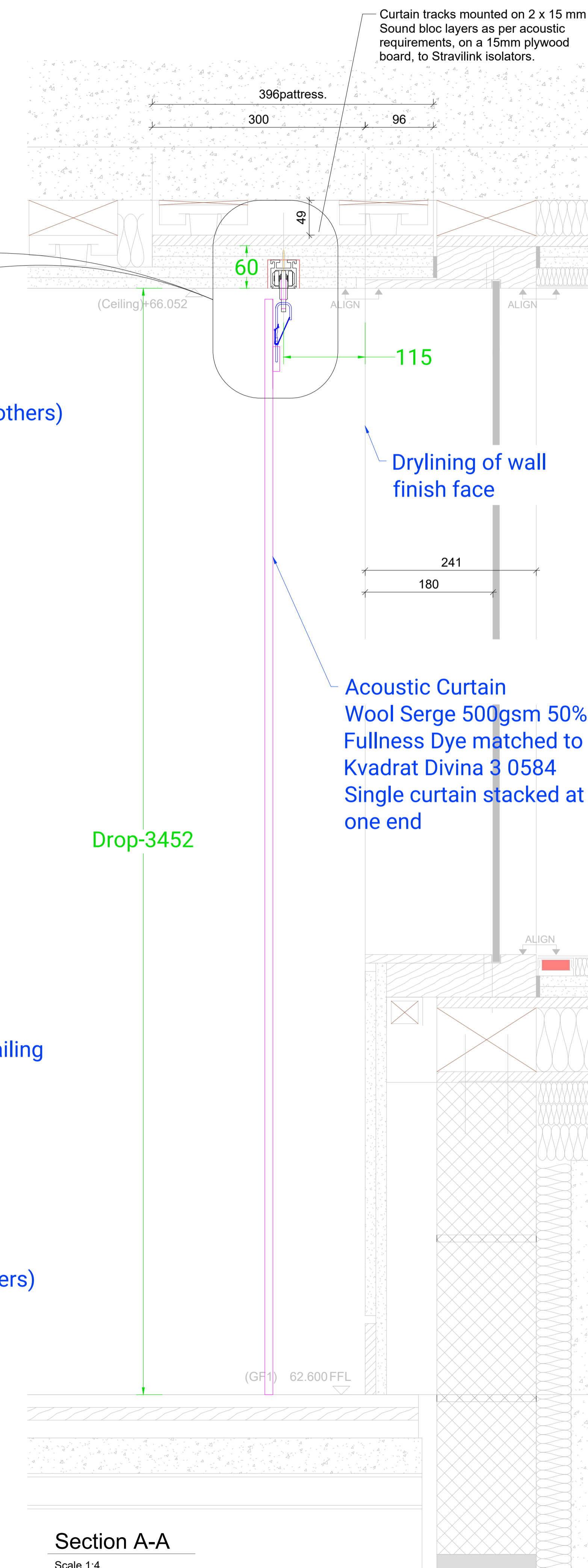

Section A-A  
 Scale 1:4

## **7. Wool Serge 565 Datapack**

Datapack shown overleaf.

# Wool Serge 565

Perfect For: Masking • Decorative/Scenic • Film & TV • Stage • Acoustics

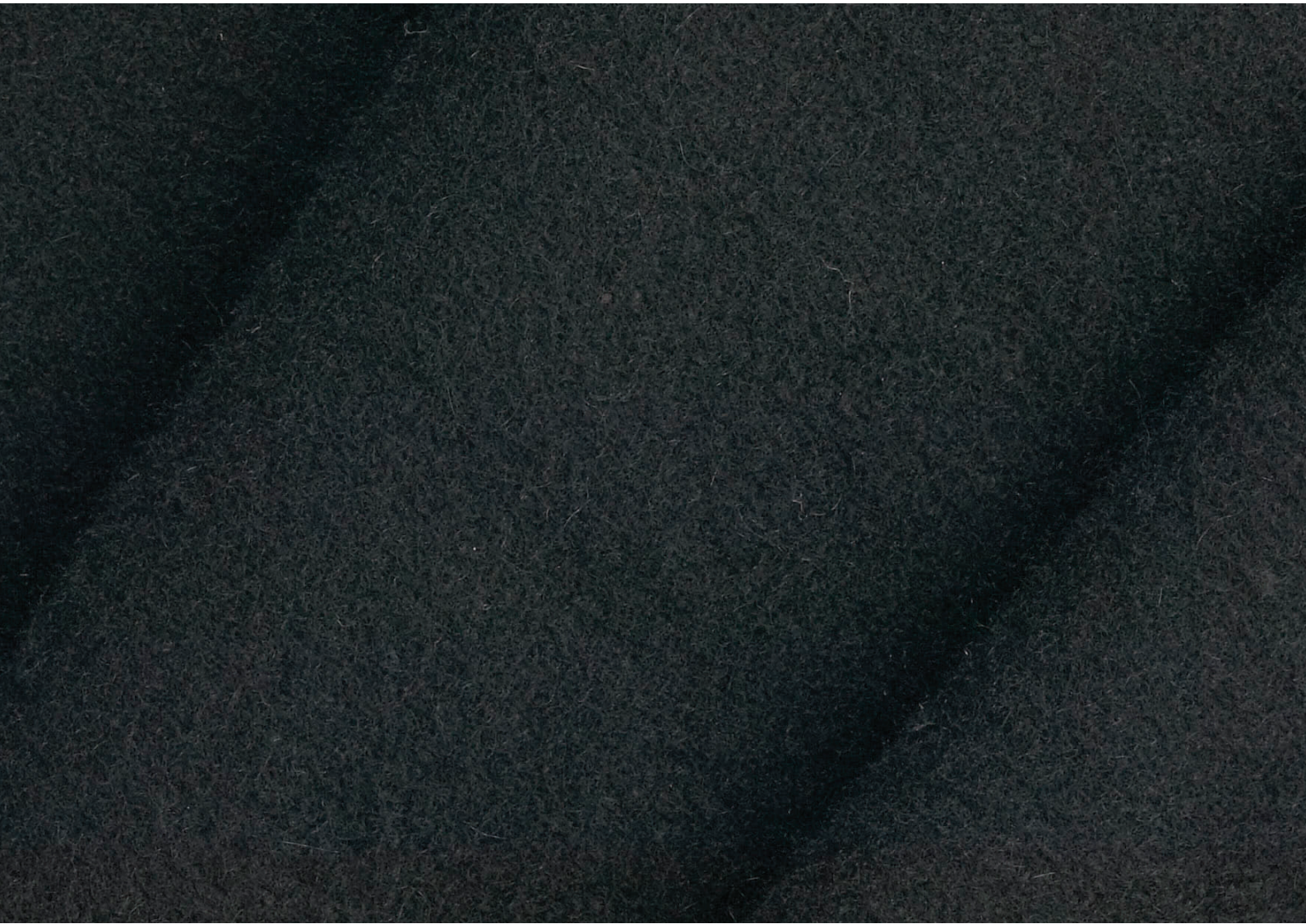

**J&C Joel** ™  
Inspiration in every performance

# Contents

## Composition & Care

150 cm	3
<b>Fire Certificate</b>	
BS5867 Part 2 Type B	4
NFPA 701	8
IMO	12
AS 1530.2	17
AS/NZS 1530.3	18

## Acoustic Test Report

Flat	20
50% Fullness	22
100% Fullness	25

## TECHNICAL



**NDFR**  
**Non Durably Flame Retardant**  
chemically treated with a water solution and if wetted in any way should be retreated



**DFR**  
**Durably Flame Retardant**  
chemically treated to withstand a number of cleanings



**IFR**  
**Inherently Flame Retardant**  
woven from fibres with a high flame retardancy



**FR**  
**Flame Retardant**  
chemically treated to an individual specification



**NOT FR**  
**Not Flame Retardant** no flame retardant treatment



Confirmation that the fabric meets one or more flame retardant standards

**BS5867** BS5867 Pt2 B is the British Standard for flame retardant fabrics used for curtains and drapes

**BS5852** BS5852 Pt1 is the British Standard for flammability of upholstered composites for seating

**BS4790** BS4790: 1987 Determination of the effects of a small source of ignition on textile floor coverings hot metal nut method (method 1, loose laid)

**EN13773: 2003** Meets European fire safety standards for vertically hung fabrics. Burning behavior, ignitability testing of curtain fabric for use in the contract market.

**TL 1080-0002/8** German Military Specification for horizontally tested materials

**EN14041** Details the requirement for CE Marking of textiles, laminate and resilient floor coverings

**BS7905-1:2001** Lifting equipment for performance, broadcast and similar applications.

## ATTRIBUTES



Approx roll length of material in linear metres (m) & feet (ft)



Approx width of material in centimetres (cm) & inches (")



Approx weight in grams per metre squared (g/m<sup>2</sup>)



Approx thickness in (mm)

**M1, M2, M4** Conforms to French Fire Regulations

**B1, B2** Conforms to German Fire Regulations DIN 4102

**IMO** Conforms to International Maritime Organisation regulations

**Classe Uno** Meets Italian Fire Regulations

**BS EN13501-1** Fire Classification of construction, products and building elements. Classification using test data from reaction to fire tests







**CFC EN ISO 9239-1** Reaction to fire test. Horizontal surface spread of flame on floor covering system. Determination of the burning behaviour using a retardant heat source







**NFPA 701** NFPA 701: (USA) Standard Methods of Fire Tests for Flame Propagation of Textiles and Films

**EN9239-1** Reaction to fire tests – horizontal surface spread of flame on floor covering systems

**DIN EN1021** Meets European fire safety standards for exposure to different ignition sources, namely a lit cigarette and butane flame. Assessment of the ignitability of upholstered furniture

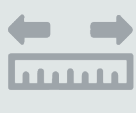
To ensure you get the best from the product supplied to you, we advise you follow the care instructions within this datasheet.

Fabric	Flame Retardancy	IFR
	Fire Certification	BS5867 Part 2 Type B, NFPA 701, IMO, AS1530.2/3
	Brand Name (and Manufacturer)	J&C Joel Ltd.
	Material (Blending Ratio)	95% Wool 5% Nylon & Other Fibres
	Construction of Fabric	Plain Weave • Yarn Count: Very Heavy • Ends/Picks: Medium Density
	Method of Dying	Fibre Dyed
Chemicals	Brand Name of Flame Retardant Chemicals	N/A
	Chemical name of Flame Retardant Chemicals	N/A
	Process of Flame Retardant Chemicals	N/A
Care	Information	<p>Inherently Flame Retardant to BS5867 Part 2 Type B, NFPA 701, IMO and AS1530.2/3. This means that the man-made fibres are flame retardant for life and if wet, would not need to be re-flameproofed. Therefore, the cloth will withstand wet cleaning but we would advise and suggest professional dry cleaning only, using the correct chemical process.</p> <p>Notwithstanding the aforementioned, it would be our advice to only dry clean this material periodically. We would suggest that the curtain be soft-brushed on a regular basis and periodically cleaned using a vacuum and drapery attachment.</p> <p>This fabric is not pre-shrunk.</p>
	Laundering Treatment	<div style="display: flex; justify-content: space-around; align-items: center;"> <div style="text-align: center;">               Dry Clean Only         </div> <div style="text-align: center;">               Do Not Wash         </div> <div style="text-align: center;">               Do Not Bleach         </div> <div style="text-align: center;">               Do Not Iron         </div> <div style="text-align: center;">               Do Not Tumble Dry         </div> </div>
Other Finishes	Pressed, Blown Finish	
Notes	 Recycled Wool Materials, Acoustic	

						
Fire Rating: IFR	Approx Roll Length: 57m / 187ft	Width: 150cm / 59"	Weight: 565 g/m <sup>2</sup>	Fire Certification: BS5867, NFPA 701, IMO, AS1530.2/3	Colours Available	Fabric Thickness: *1.90mm

\*FABRIC THICKNESS Measured in-house with digital callipers, not under laboratory conditions.

For further information please contact our sales team [sales@jcjoel.com](mailto:sales@jcjoel.com)

# Fire Test Certificate – Specimen

**Fabric:** Wool Serge 565  
**Type:** BS5867 Part 2 Type B

**J&C Joel**   
Inspiration in every performance



Wira House, West Park Ring Road, Leeds, LS16 6QL, UK.  
Telephone: +44 (0) 113 259 1999  
Email: [onestopshop@bttg.co.uk](mailto:onestopshop@bttg.co.uk)  
Website: [www.bttg.co.uk](http://www.bttg.co.uk)

Date: 27 June 2022  
Our Ref: 23/59842A/06/22  
Your Ref: ---  
Page: 1 of 4

**Client:** **J&C Joel Ltd**  
Corporation Mill  
Corporation Street  
Sowerby Bridge  
Halifax  
HX6 2QQ

**Job Title:** Fire Test on One Fabric Sample

**Clients Order Ref:** 67711

**Date of Receipt:** 16 June 2022

**Date Test Started:** 24 June 2022

**Description of Sample:** One sample of fabric, which was referenced by the client as;  
WS090 Premier Wool Serge

**Work Requested:** We were asked to make the following fire test:  
BS 5867:Part 2:Type B:2008 (2015)

- \* subcontracted test, UKAS accredited
- \*\* subcontracted test, EN ISO/IEC 17025 accredited
- \*\*\* not UKAS accredited



1066

Note: This report relates only to the items tested.

Shirley® Technologies Limited. Registered Office: Wira House, West Park Ring Road, Leeds, LS16 6QL.  
A company registered in England & Wales with company number 04669651. VAT Number GB 816764800.  
BTTG™ and Shirley® are trade names of Shirley Technologies Ltd.  
The supply of all goods and services is subject to our standard terms of business, copies of which are available on request.  
Our laboratories are accredited to EN ISO/IEC 17025.

Copyright © 2022 Shirley Technologies Limited. All rights reserved.

# Fire Test Certificate – Specimen

**Fabric:** Wool Serge 565  
**Type:** BS5867 Part 2 Type B

**J&C Joel**   
Inspiration in every performance



Wira House, West Park Ring Road, Leeds, LS16 6QL, UK.  
Telephone: +44 (0) 113 259 1999  
Email: [onestopshop@bttg.co.uk](mailto:onestopshop@bttg.co.uk)  
Website: [www.bttg.co.uk](http://www.bttg.co.uk)

Date: 27 June 2022  
Our Ref: 23/59842A/06/22  
Your Ref: ---  
Page: 2 of 4

**Client:** J&C Joel Ltd

## BS 5867: Part 2: 2008 (2015): Type B Curtains, Drapes and Blinds

### Conditioning

The test specimens were conditioned for at least 24 hours in the standard atmosphere of  $65 \pm 5$  % relative humidity and  $20 \pm 2$  °C.

### Testing as received

Three specimens from both length and width were tested in accordance with BS EN ISO 15025:Procedure A (surface ignition):2002. The sample was tested at 20°C and 55% relative humidity.

Each specimen was subjected to an applied flame using propane and a 15 second flame application time. The results obtained (shown in the table below) were assessed according to the requirements of BS 5867:Part 2:Type B:2008 (2015).

### Pre-treatment

If the fabric is a pass in the 'as received' condition then the fabric is subjected a water soak and drying procedure as specified in BS EN 1021-1 & 2:Annex D:2006.

### Testing after pre-treatment

Three specimens, after pre-treatment, from both length and width were tested following the procedure described above.



Shirley® Technologies Limited. Registered Office: Wira House, West Park Ring Road, Leeds, LS16 6QL.  
A company registered in England & Wales with company number 04669651. VAT Number GB 816764800.  
BTTG™ and Shirley® are trade names of Shirley Technologies Ltd.  
The supply of all goods and services is subject to our standard terms of business, copies of which are available on request.  
Our laboratories are accredited to EN ISO/IEC 17025.

Copyright © 2022 Shirley Technologies Limited. All rights reserved.

# Fire Test Certificate – Specimen

**Fabric:** Wool Serge 565  
**Type:** BS5867 Part 2 Type B

**J&C Joel**   
Inspiration in every performance



Wira House, West Park Ring Road, Leeds, LS16 6QL, UK.  
Telephone: +44 (0) 113 259 1999  
Email: [onestopshop@bttg.co.uk](mailto:onestopshop@bttg.co.uk)  
Website: [www.bttg.co.uk](http://www.bttg.co.uk)

Date: 27 June 2022

Our Ref: 23/59842A/06/22  
Your Ref: ---

Page: 3 of 4

**Client:** J&C Joel Ltd

## Results - Testing as Received:

Specimen No.	Length			Width		
	1	2	3	4	5	6
Flame reached an edge	No	No	No	No	No	No
Hole reached an edge	No	No	No	No	No	No
Flaming debris separated	No	No	No	No	No	No
Afterflame (s)	0	0	0	10	0	1
Afterglow (s)	0	0	0	0	0	0

Requirements - Any "Yes" means fail except if only one specimen fails a further 6 specimens are tested, if the second 6 specimens all pass the result is a pass.

**Result in 'as received': Pass**

## Results - Testing after pre-treatment:

Specimen No.	Length			Width		
	1	2	3	4	5	6
Flame reached an edge	No	No	No	No	No	No
Hole reached an edge	No	No	No	No	No	No
Flaming debris separated	No	No	No	No	No	No
Afterflame (s)	0	0	0	0	0	0
Afterglow (s)	0	0	0	0	0	0

Requirements - Any "Yes" means fail except if only one specimen fails a further 6 specimens are tested, if the second 6 specimens all pass the result is a pass.

**Result in 'after pre-treatment': Pass**



Shirley® Technologies Limited. Registered Office: Wira House, West Park Ring Road, Leeds, LS16 6QL.  
A company registered in England & Wales with company number 04669651. VAT Number GB 816764800.  
BTTG™ and Shirley® are trade names of Shirley Technologies Ltd.  
The supply of all goods and services is subject to our standard terms of business, copies of which are available on request.  
Our laboratories are accredited to EN ISO/IEC 17025.

Copyright © 2022 Shirley Technologies Limited. All rights reserved.

# Fire Test Certificate – Specimen

**Fabric:** Wool Serge 565  
**Type:** BS5867 Part 2 Type B

**J&C Joel**   
Inspiration in every performance



Wira House, West Park Ring Road, Leeds, LS16 6QL, UK.  
Telephone: +44 (0) 113 259 1999  
Email: [onestopshop@bttg.co.uk](mailto:onestopshop@bttg.co.uk)  
Website: [www.bttg.co.uk](http://www.bttg.co.uk)

Date: 27 June 2022

Our Ref: 23/59842A/06/22  
Your Ref: ---

Page: 4 of 4

Client: J&C Joel Ltd

## Comment

The fabric meets the Type B performance requirements of BS 5867: Part 2: Type B:2008 (2015).

This material should be identified with the manufacturers name, trademark or other identifying mark, the statement 'Flammability complies with the requirements of BS 5867: Part 2:Type B and instructions of any special precautions to be taken concerning care (including cleansing) of the curtain, drape or window blind to be manufactured from the fabric, preferably using an appropriate care labelling symbol in accordance with BS EN 23758 and taking account of the pre-treatment using in this test and the requirements of Clause 4 of BS 5867:Part 2:2008 (2015). If the fabric is unsuitable for cleansing, this shall be stated.

Where required to make a judgement to any pass/fail criteria an estimation of uncertainty of measurement has been taken into account. Under our Policy we have used a non-binary decision rule.

See our decision rules Policy (<http://www.bttg.co.uk/decision-rules-policy>) for further information.

## Uncertainty Budget

Measurements are not taken and pass/fail is related to flame extremities and flaming debris, as such any risk of false acceptance/false rejection is inherent with this standard and would be outside of 95% probability in any case. As such UoM is Zero providing all input parameters are correct.

There is no uncertainty budget associated with BS 5867:Part 2:Type B as no measurements are determined , the pass/fail criteria is assessed visually.

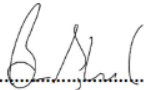
Reported by:  B Bland, Technical Customer Service Officer

Countersigned by:  P Doherty, Manager

Enquiries concerning this report should be addressed to Customer Services.



1066

Shirley® Technologies Limited. Registered Office: Wira House, West Park Ring Road, Leeds, LS16 6QL.  
A company registered in England & Wales with company number 04669651. VAT Number GB 816764800.  
BTTG™ and Shirley® are trade names of Shirley Technologies Ltd.  
The supply of all goods and services is subject to our standard terms of business, copies of which are available on request.  
Our laboratories are accredited to EN ISO/IEC 17025.

Copyright © 2022 Shirley Technologies Limited. All rights reserved.

# Fire Test Certificate – Specimen

**Fabric:** Wool Serge 565  
**Type:** NFPA 701



96-D Allen Boulevard  
 Farmingdale, New York 11735-5626 USA  
 Tel. +1 (631) 293-8944 Fax +1 (631) 293-8956  
 e-mail: info@govmark.com

Page 1

Received: 03/31/2014	Completed: 04/02/2014	Letter: C	BG	P.O.#: 9556	Test Report #:	3-01380-0-
<b>Client's Identification</b>	Style: Wool Serge. Content: 100% wool. Width: 150 cm. Finish: dyed and treated with flame retardant solution. Weight: 565 grams / sq. meter. End Use: Stage draperies.					
<b>Tested For:</b> Andrew Walsh	<b>Key Test:</b> NFPA 701-2010 TM#1				205	
J & C Joel, Ltd. Corporation Mill, Corporation St.UK Sowerby Brdg, Halifax, W Yorkshire			Tel: 011 422 833 835 Fax: 011 422 835 137		Ext:	

PC: 0.5H DL/jd

TEST PERFORMED: NFPA 701 - Standard Methods of Fire Tests for Flame Propagation of Textiles and Films - 2010 Edition - Test Method #1

PRODUCT CONFIGURATION:  Single Layer;  Multi Layer

RESULTS REPORTED:  Initially;  After 3 dry cleanings;  After 5 launderings @ 160°F

**RESULTS:**

Specimen #	Afterflame* (seconds)	Flaming Drip (seconds)	Weight Loss (percent)
1	0	0	6.7
2	0	0	5.9
3	0	0	6.0
4	0	0	6.5
5	0	0	5.3
6	0	0	6.9
7	0	0	6.0
8	0	0	7.2
9	0	0	6.5
10	0	0	7.1
Mean:	0	Mean:	6.4

STATISTICAL VALUES: SD = 0.6 3 SD = 1.8 Mean + 3 SD = 8.3

ABBREVIATIONS USED: SD = Standard deviation. NT = Not tested.

APPROXIMATE WEIGHT OF MATERIAL (as measured by Govmark): 590g/m<sup>2</sup>

PRECONDITIONING:  0.5 hr @ 220°F (Standard)  
 24 hrs @ 68±9°F (Alternate: Material shrinks/distorts @ 220°F)

CONVERSION FACTOR: g/m<sup>2</sup> ÷ 28.35 x .835 = oz/yd<sup>2</sup>

**NOTE:**

1. All specimens prepared in the length direction.
2. See addendum for individual specimen weights.

(Page 1 of 3)

File Copy

# Fire Test Certificate – Specimen

**Fabric:** Wool Serge 565  
**Type:** NFPA 701

**J&C Joel**   
 Inspiration in every performance



96-D Allen Boulevard  
 Farmingdale, New York 11735-6626 USA  
 Tel. +1 (631) 293-8944 Fax +1 (631) 293-8956  
 e-mail: info@govmark.com

Page 2

Received: 03/31/2014	Completed: 04/02/2014	Letter: C	BG	P.O.#: 9556	Test Report #:	3-01380-0-
Client's Identification	Style: Wool Serge. Content: 100% wool. Width: 150 cm. Finish: dyed and treated with flame retardant solution. Weight: 565 grams / sq. meter. End Use: Stage draperies.					
Tested For: Andrew Walsh	J & C Joel, Ltd. Corporation Mill, Corporation St.UK Sowerby Brdg, Halifax, W Yorkshire				Key Test: NFPA 701-2010 TM#1	205
				Tel: 011 422 833 835	Ext:	
				Fax: 011 422 835 157		

**REMARKS:**

- Flames did not project above the top of the specimen.
- Flames projected above the top of the specimen; Specimen #'s \_\_\_\_\_
- Other: \_\_\_\_\_

**FAILURE CRITERIA:** As cited by NFPA 701 - 2010 Edition Test Method #1

Afterflame	Flaming Drip (Mean)	Weight Loss (percent)	
		Mean	Individual Specimen
*	Exceeds 2 seconds	Exceeds 40%	Exceeds Mean + 3 SD**

**CONCLUSION:** Based on the Results on page 1 and the above Failure Criteria cited by NFPA 701 - 2010 Edition Test Method #1, the item tested:

- Passes;  Fails;  Requires testing of 10 additional specimens  
 i.e. only one individual specimen failure was noted

\* Afterflame is required to be recorded; however, the NFPA document does not factor it into the Failure Criteria reporting requirements. It should be noted that excessive afterflames (15 seconds or more) could be cause for rejection by local fire authorities performing "match" field tests.

\*\* See "Discussion" on Page 3.

**CERTIFICATION:** I certify that the above results were obtained after testing specimens in accordance with the procedures and equipment specified by NFPA 701 - 2010 Edition Test Method #1.

  
 \_\_\_\_\_  
 AUTHORIZED SIGNATURE  
 THE GOVMARK ORGANIZATION, INC. /je km  
**MS. PHYLLIS PETTIT**

APR 09 2014

JCJ/ROS-NJ-2

(Page 2 of 3)

File Copy

# Fire Test Certificate – Specimen

**Fabric:** Wool Serge 565  
**Type:** NFPA 701

**J&C Joel**   
Inspiration in every performance



96-D Allen Boulevard  
Farmingdale, New York 11735-5626 USA  
Tel. +1 (631) 293-8944 Fax +1 (631) 293-8956  
e-mail: info@govmark.com

Page 3

Received:03/31/2014	Completed:04/02/2014	Letter: C	BG	P.O.#: 9556	Test Report #:	3-01380-0-
Client's Identification	Style: Wool Serge. Content: 100% wool. Width: 150 cm. Finish: dyed and treated with flame retardant solution. Weight: 565 grams / sq. meter. End Use: Stage draperies.					
Tested For: Andrew Walsh	J & C Joel, Ltd. Corporation Mill, Corporation St.UK Sowerby Brdg,Hallifax,W Yorkshire			Key Test: NFPA 701-2010 TM#1	205	
				Tel: 011 422 833 835	Ext:	
				Fax: 011 422 835 157		

**\*\* DISCUSSION:**

**Weight Loss - Individual Specimen Failure:**

-----  
The NFPA 701 document, as written, provides for a statistical calculation which provides for retest and a potential failure if any individual value exceeds the mean by three standard deviations. Govmark is of the opinion that this cannot mathematically occur, i.e. no individual result is mathematically capable of exceeding the mean plus three standard deviations. Therefore, in effect, Govmark is of the opinion that this "individual specimen criteria" has no meaning, since it cannot possibly result in a nonconformance.

(Page 3 of 3)

The results contained in this report relate only to item(s) tested. The test report shall not be reproduced, except in full, without written approval from The Govmark Organization, Inc.

*File Copy*

# Fire Test Certificate – Specimen

Fabric: Wool Serge 565  
Type: NFPA 701

**J&C Joel**   
Inspiration in every performance



96D Allen Blvd.  
Farmingdale, NY 11735  
TEL: (516) 293-8944  
FAX: (516) 293-8956

Client Name : J&C Joel  
Addendum to Test Report # : 3-01380-0  
Test : NFPA 701

Specimen #	Weight Before Test ( g )	Weight After Test ( g )	Percent Weight Loss
1	32.60	30.40	6.7
2	33.80	31.80	5.9
3	33.20	31.20	6.0
4	34.00	31.80	6.5
5	33.80	32.00	5.3
6	34.60	32.20	6.9
7	33.60	31.60	6.0
8	33.20	30.80	7.2
9	33.60	31.40	6.5
10	33.60	31.20	7.1

Mean Percent Weight Loss : 6.4  
Standard Deviation : 0.6  
3 x Standard Deviation : 1.8  
Mean + 3 x Standard Deviation : 8.3

APR 09 2014 

# Fire Test Certificate – Specimen

**Fabric:** Wool Serge 565  
**Type:** IMO

**J&C Joel**   
Inspiration in every performance



Wira House, West Park Ring Road, Leeds, LS16 6QL, UK.  
Telephone: +44 (0) 113 259 1999  
Email: [info@bttg.co.uk](mailto:info@bttg.co.uk)  
Website: [www.bttg.co.uk](http://www.bttg.co.uk)

Date: 24 July 2019

Our Ref: 56634-1

Your Ref: -

Page: 1 of 5

Client: J. & C. Joel Limited  
Corporation Mill  
Corporation Street  
Sowerby Bridge  
Halifax  
HX6 2QQ

Job Title: Fire Test on One Sample of Fabric

Client's Order No: 57441

Date of Receipt: 17 July 2019

Description of Sample(s): One sample of fabric, referenced;  
Premier Wool Serge

Work Requested: We were asked to make the following test(s):  
IMO FTP Code 2010 Part 7

- \* subcontracted test, UKAS accredited
- \*\* subcontracted test, EN ISO/IEC 17025 accredited
- \*\*\* not UKAS accredited



Shirley® Technologies Limited. Registered Office: Wira House, West Park Ring Road, Leeds, LS16 6QL.  
A company registered in England & Wales with company number 04669651. VAT Number GB 816764800.  
BTTG™ and Shirley® are trade names of Shirley Technologies Limited  
The supply of all goods and services is subject to our standard terms of business, copies of which are available on request.  
Our laboratories are accredited to EN ISO/IEC 17025.  
Copyright © 2020 Shirley Technologies Limited. All rights reserved.

# Fire Test Certificate – Specimen

**Fabric:** Wool Serge 565  
**Type:** IMO

**J&C Joel**   
Inspiration in every performance



TESTING • CERTIFICATION • AUDITING

Client: J. & C. Joel Limited

Wira House, West Park Ring Road, Leeds, LS16 6QL, UK.  
Telephone: +44 (0) 113 259 1999  
Email: [info@btg.co.uk](mailto:info@btg.co.uk)  
Website: [www.btg.co.uk](http://www.btg.co.uk)

Date: 24 July 2019

Our Ref: 56634-1

Your Ref: -

Page: 2 of 5

## Product Description

Company Name	J & C Joel Ltd
Type of Material, i.e. Curtain, Drape, etc.	Curtain/Draperly Fabric
Name and/or Identification of the Product Tested	Premier Wool Serge
Mass per Unit Area (g/m <sup>2</sup> )	565gsm
Thickness (mm)	2mm
Colour and Tone (i)	Black
Quantity and Number of Any Coating	None
Method and Quantity of Fire Retardant Treatment	Inherently Flame-retardant
Materials of the Product and its Composite Ratio (ii)	90% Wool - 10% OF
Composition of Weave (iii)	Twill
Density (Number/Inch) the Number of Threads per Inch in both warp and weft; and	---
Yarn Number Count	---

- (i) If the product has a pattern, the representative colour shall be described.  
(ii) Such as wool, nylon, polyester, etc.  
(iii) Such as plain, weave, twilled;



Shirley® Technologies Limited. Registered Office: Wira House, West Park Ring Road, Leeds, LS16 6QL.  
A company registered in England & Wales with company number 04669651. VAT Number GB 816764800.  
BTTG™ and Shirley® are trade names of Shirley Technologies Limited  
The supply of all goods and services is subject to our standard terms of business, copies of which are available on request.  
Our laboratories are accredited to EN ISO/IEC 17025.  
Copyright © 2020 Shirley Technologies Limited. All rights reserved.

# Fire Test Certificate – Specimen

**Fabric:** Wool Serge 565  
**Type:** IMO

**J&C Joel**   
Inspiration in every performance



TESTING • CERTIFICATION • AUDITING

Client: J. & C. Joel Limited

Wira House, West Park Ring Road, Leeds, LS16 6QL, UK.  
Telephone: +44 (0) 113 259 1999  
Email: [info@bttg.co.uk](mailto:info@bttg.co.uk)  
Website: [www.bttg.co.uk](http://www.bttg.co.uk)

Date: 24 July 2019

Our Ref: 56634-1  
Your Ref: -

Page: 3 of 5

## FIRE TESTS ACCORDING to IMO FTP Code 2010:Part 7 Test for Vertically Supported Textiles and Films

### Cleaning Procedure

The sample received no pre-treatment as the fabric is stated to be inherently flame retardant.

### Conditioning

The sample was conditioned for 72 hours in the standard atmosphere for conditioning textiles of  $20 \pm 5^\circ\text{C}$  and  $65 \pm 5\%$  R.H.

### Procedure

The sample was tested in accordance with IMO FTP Code 2010:Part 7. The sponsor sampled the material and the specimens were cut from the sample received to the dimensions set out in the standard.

A 40mm high propane gas flame was applied to the edge of 5 warp and 5 weft specimens for 5 seconds.

The after-flame time, length of char, existence of surface flashing and ignition of cotton waste from drops were recorded.

### Requirements

The Performance Criteria for Curtains and Drapes states that: Products which show any of the following characteristics obtained by the fire test in appendix 1, shall be considered unsuitable for use as curtains, drapes or free-hanging fabric product for use in rooms containing furniture and furnishings of restricted fire risk as defined in the relevant regulations of chapter II-2 of the Convention:-

1. An after-flame time greater than 5 sec for any of the 10 or more specimens tested with surface application of the pilot flame.
2. Burn through to any edge of any of the 10 or more specimens tested with surface application of the pilot flame.
3. Ignition of cotton wool below specimen in any of the 10 or more specimens tested.
4. An average char length in excess of 150mm observed in any of the 10 or more specimens tested by either surface or edge ignition; and
5. The occurrence of a surface flash propagating more than 100mm from the point of ignition with or without charring of the base fabric.

If it is found that either or both of the batches of five specimens cut in both warp and weft directions fail to meet one or more of the criteria specified in subparagraphs .1 to .3 and .5 above because of poor performance of only one of the five specimens tested, one complete retest of a similar batch is permitted. Failure of the second batch to meet any of the criteria shall provide the basis for rejection of the fabric for use.



Shirley® Technologies Limited. Registered Office: Wira House, West Park Ring Road, Leeds, LS16 6QL.  
A company registered in England & Wales with company number 04669651. VAT Number GB 816764800.  
BTTG™ and Shirley® are trade names of Shirley Technologies Limited  
The supply of all goods and services is subject to our standard terms of business, copies of which are available on request.  
Our laboratories are accredited to EN ISO/IEC 17025.  
Copyright © 2020 Shirley Technologies Limited. All rights reserved.

# Fire Test Certificate – Specimen

**Fabric:** Wool Serge 565  
**Type:** IMO



TESTING • CERTIFICATION • AUDITING

Client: J. & C. Joel Limited

Wira House, West Park Ring Road, Leeds, LS16 6QL, UK.  
 Telephone: +44 (0) 113 259 1999  
 Email: [info@bttg.co.uk](mailto:info@bttg.co.uk)  
 Website: [www.bttg.co.uk](http://www.bttg.co.uk)

Date: 24 July 2019

Our Ref: 56634-1

Your Ref: -

Page: 4 of 5

**As Received**

	After flame time (s)		Char length (mm)		Flaming to edge (yes or No)		Ignition of Cotton Wool from Flaming Drops (Yes or No)		Surface Flashing (Yes or No), if yes, Propagation Length (mm)	
	Warp	Weft	Warp	Weft	Warp	Weft	Warp	Weft	Warp	Weft
	0	0	34	40	No	No	No	No	No	No
	0	0	39	39	No	No	No	No	No	No
	0	1	40	36	No	No	No	No	No	No
	3	0	37	35	No	No	No	No	No	No
	0	0	34	37	No	No	No	No	No	No
Mean	1	0	37	37						

**Comment**

The results indicate the sample meets the requirements according to IMO 2010 FTP Code, Part 7.

This report relates only to the samples submitted and as described in the report.

Uncertainty of measurement has not been taken into account when presenting the test result. The relevant uncertainty value is included as an annex which forms an integral part of the report.

Reported by:   
 B Bland  
 Laboratory Technician

Countersigned By:   
 P Doherty  
 Manager



Shirley\* Technologies Limited. Registered Office: Wira House, West Park Ring Road, Leeds, LS16 6QL.  
 A company registered in England & Wales with company number 04669651. VAT Number GB 816764800.  
 BTTG™ and Shirley® are trade names of Shirley Technologies Limited  
 The supply of all goods and services is subject to our standard terms of business, copies of which are available on request.  
 Our laboratories are accredited to EN ISO/IEC 17025.  
 Copyright © 2020 Shirley Technologies Limited. All rights reserved.

# Fire Test Certificate – Specimen

**Fabric:** Wool Serge 565  
**Type:** IMO

**J&C Joel**   
Inspiration in every performance



TESTING • CERTIFICATION • AUDITING

Client: J. & C. Joel Limited

Wira House, West Park Ring Road, Leeds, LS16 6QL, UK.  
Telephone: +44 (0) 113 259 1999  
Email: [info@bttg.co.uk](mailto:info@bttg.co.uk)  
Website: [www.bttg.co.uk](http://www.bttg.co.uk)

Date: 24 July 2019

Our Ref: 56634-1

Your Ref: -

Page: 5 of 5

## Uncertainty Budget - Annex

The overall uncertainty budget IMO FTP Code 2010:Part 7 is as follows:-

Measurements:  $\pm 1\text{mm}$   
Duration of Flaming:  $\pm 0.5\text{ seconds}$

SPECIMEN



Shirley\* Technologies Limited. Registered Office: Wira House, West Park Ring Road, Leeds, LS16 6QL.  
A company registered in England & Wales with company number 04669651. VAT Number GB 816764800.  
BTG™ and Shirley\* are trade names of Shirley Technologies Limited  
The supply of all goods and services is subject to our standard terms of business, copies of which are available on request.  
Our laboratories are accredited to EN ISO/IEC 17025.  
Copyright © 2020 Shirley Technologies Limited. All rights reserved.

# Fire Test Certificate – Specimen

**Fabric:** Wool Serge 565  
**Type:** AS 1530.2

**J&C Joel**   
Inspiration in every performance

## AWTA PRODUCT TESTING

Australian Wool Testing Authority Ltd - trading as AWTA Product Testing  
A.B.N 43 006 014 106  
1st Floor, 191 Racecourse Road, Flemington, Victoria 3031  
P.O Box 240, North Melbourne, Victoria 3051  
Phone (03) 9371 2400 Fax (03) 9371 2499

### TEST REPORT

**Client :** J & C Joel Ltd  
Corporation Mill, Corporation Street  
Sowerby Bridge, Halifax, HX6 2QQ  
ENGLAND

**Test Number :** 18-002989  
**Issue Date :** 6/06/2018  
**Print Date :** 18/06/2018

**Sample Description** Clients Ref : "Premier Wool Serge"  
Milled woven woollen fabric  
End Use : Curtains & Drapery  
Nominal Composition : 100% Wool  
Nominal Mass per Unit Area/Density : 565g/m2  
Nominal Thickness : 2.5mm

AS 1530.2-1993

**Methods for Fire Tests on Building Materials, Components and Structures.  
Part 2: Test for Flammability of Materials**

Date Tested	06/06/2018	
Flammability Index	6	
	Length	Width
Spread Factor	3	5
Heat Factor	1	1
Maximum height (d)		
Mean	4.4	5.4
Coefficient of Variation	18.1	14.8 %
Heat (a)		
Mean	3.3	4.0 °C.min
Coefficient of Variation	18.2	5.0 %
Number of Specimens Tested	6	6
Observation	Melting and visible smoke	

These test results relate only to the behaviour of the test specimens of the material under the particular conditions of the test, and they are not intended to be the sole criterion for assessing the potential fire hazard of the material in use.

132359

28114

Page 1 of 1

© Australian Wool Testing Authority Ltd  
Copyright - All Rights Reserved



Accredited for compliance with ISO/IEC 17025 - Testing  
- Chemical Testing  
- Mechanical Testing  
- Performance & Approvals Testing

: Accreditation No. 983  
: Accreditation No. 985  
: Accreditation No. 1356



Samples and their identifying descriptions have been provided by the client unless otherwise stated. AWTA Ltd makes no warranty, implied or otherwise, as to the source of the tested samples. The above test results relate only to the sample or samples tested. This document shall not be reproduced except in full and shall be rendered void if amended or altered. This document, the names AWTA Product Testing and AWTA Ltd may be used in advertising providing the content and format of the advertisement have been approved by the Managing Director of AWTA Ltd.

0204/11/06

  
APPROVED SIGNATORY

  
MICHAEL A. JACKSON B.Sc.(Hons)  
MANAGING DIRECTOR

# Fire Test Certificate – Specimen

**Fabric:** Wool Serge 565  
**Type:** AS/NZS 1530.3

**J&C Joel**   
Inspiration in every performance

## AWTA PRODUCT TESTING

Australian Wool Testing Authority Ltd - trading as AWTA Product Testing  
A.B.N 43 006 014 106  
1st Floor, 191 Racecourse Road, Flemington, Victoria 3031  
P.O Box 240, North Melbourne, Victoria 3051  
Phone (03) 9371 2400 Fax (03) 9371 2499

### TEST REPORT

**Client :** J & C Joel Ltd  
Corporation Mill, Corporation Street  
Sowerby Bridge, Halifax, HX6 2QQ  
ENGLAND

**Test Number :** 18-003051  
**Issue Date :** 20/06/2018  
**Print Date :** 20/06/2018

**Sample Description** Clients Ref : "Premier Wool Serge"  
Milled woven woollen fabric  
End Use : Curtains & Drapery  
Nominal Composition : 100% Wool  
Nominal Mass per Unit Area/Density : 565g/m2  
Nominal Thickness : 2.5mm

AS/NZS 1530.3-1999

#### Methods for Fire Tests on Building Materials, Components and Structures Part 3: Simultaneous Determination of Ignitability, Flame Propagation, Heat Release and Smoke Release

Face tested:	Face		
Date tested:	15/06/2018		
	Standard Error		Mean
Ignition time	Nil		Nil min
Flame propagation time	Nil		Nil sec
Heat release integral	Nil		Nil kJ/m <sup>2</sup>
Smoke release, log d	0.0197		-1.0172
Optical density, d			0.0966 / metre
Number of specimens ignited:			0
Number of specimens tested:			6
Regulatory Indices:			
Ignitability Index			0 Range 0-20
Spread of Flame Index			0 Range 0-10
Heat Evolved Index			0 Range 0-10
Smoke Developed Index			4 Range 0-10

132650 28177

Page 1 of 2

© Australian Wool testing Authority Ltd  
Copyright - All Rights Reserved



Accredited for compliance with ISO/IEC 17025 - Testing

- Chemical Testing  
- Mechanical Testing  
- Performance & Approvals Testing

: Accreditation No. 983  
: Accreditation No. 985  
: Accreditation No. 1356



Samples and their identifying descriptions have been provided by the client unless otherwise stated. AWTA Ltd makes no warranty, implied or otherwise, as to the source of the tested samples. The above test results relate only to the sample or samples tested. This document shall not be reproduced except in full and shall be rendered void if amended or altered. This document, the names AWTA Product Testing and AWTA Ltd may be used in advertising providing the content and format of the advertisement have been approved by the Managing Director of AWTA Ltd.

0204/11/06

  
APPROVED SIGNATURE

  
MICHAEL A. JACKSON B.Sc. (Hons)  
MANAGING DIRECTOR

# Fire Test Certificate – Specimen

**Fabric:** Wool Serge 565  
**Type:** AS/NZS 1530.3

**J&C Joel**   
Inspiration in every performance

## AWTA PRODUCT TESTING

Australian Wool Testing Authority Ltd - trading as AWTA Product Testing  
A.B.N 43 006 014 106  
1st Floor, 191 Racecourse Road, Flemington, Victoria 3031  
P.O Box 240, North Melbourne, Victoria 3051  
Phone (03) 9371 2400 Fax (03) 9371 2499

### TEST REPORT

**Client :** J & C Joel Ltd  
Corporation Mill, Corporation Street  
Sowerby Bridge, Halifax, HX6 2QQ  
ENGLAND

**Test Number :** 18-003051  
**Issue Date :** 20/06/2018  
**Print Date :** 20/06/2018

These results only apply to the specimen mounted, as described in this report. The result of this fire test may be used to directly assess fire hazard, but it should be recognised that a single test method will not provide a full assessment of fire hazard under all fire conditions.

Ignition is initiated by a pilot flame that is held near, but does not touch the specimen. A material that does not ignite during the standard test may ignite if contacted with a pilot flame during the test.

The specimens were mounted to simulate use in an unsupported or free hanging mode. The results may be significantly different when mounted to simulate a wall cladding or upholstery application.

To allow free movement of sample during testing all corners were folded away from the clamps.

Each test specimen was sandwiched between two layers of galvanised welded square mesh made from wire of nominal diameter 0.8mm and nominal spacing 12mm in both directions, stapled through at four points, each 100mm from the centre of the sample and the assembly clamped in four places.

132650

28177

Page 2 of 2

Australian Wool testing Authority Ltd  
Copyright - All Rights Reserved



Accredited for compliance with ISO/IEC 17025 - Testing

- Chemical Testing  
- Mechanical Testing  
- Performance & Approvals Testing

: Accreditation No. 983  
: Accreditation No. 985  
: Accreditation No. 1356



Samples and their identifying descriptions have been provided by the client unless otherwise stated. AWTA Ltd makes no warranty, implied or otherwise, as to the source of the tested samples. The above test results relate only to the sample or samples tested. This document shall not be reproduced except in full and shall be rendered void if amended or altered. This document, the names AWTA Product Testing and AWTA Ltd may be used in advertising providing the content and format of the advertisement have been approved by the Managing Director of AWTA Ltd.

# Acoustic Test Report - Absorption

**Absorption Class:** D

Calculated to EN ISO 11654:1997

**Fabric:** Wool Serge 565

**Fullness:** Flat

**Cavity from Wall:** 100mm



Inspiration in every performance

## Data Sheet 9

The Laboratory Measurement of Random Incidence Sound Absorption generally to BS EN ISO 354:2003

**Client:** J&C Joel Ltd

**Test Date:** 12/04/2014

**Empty Room:** **Temperature:** 17.0 °C **Humidity:** 57 %RH **Pressure:** 1010 mbar

**Room with Sample:** **Temperature:** 16.7 °C **Humidity:** 50 %RH **Pressure:** 1009 mbar

**Sample Description:** Wool Serge 565 - Single Layer – Flat (Approx. weight 565g/m<sup>2</sup>) – 100mm cavity from wall

**Mounting Method:** G-100

**Sample Area:** 9 m<sup>2</sup>

**Chamber Volume:** 300 m<sup>3</sup>

### Test 10

Freq Hz	T1 sec	T2 sec	Absorp Coeff	Practical Absorp Coeff #
50*	5.07	5.34	-0.05	
63*	4.60	4.75	-0.04	n/a
80*	5.86	5.27	0.10	
100	6.96	6.70	0.03	
125	7.22	6.73	0.05	0.05
160	6.82	5.92	0.12	
200	6.37	5.61	0.11	
250	7.19	5.28	0.27	0.25
315	7.06	4.95	0.33	
400	6.40	4.16	0.46	
500	5.35	3.50	0.54	0.55
630	5.03	3.02	0.72	
800	5.43	3.01	0.80	
1000	5.96	3.06	0.86	0.80
1250	5.70	3.09	0.80	
1600	5.08	2.98	0.74	
2000	4.62	2.96	0.63	0.70
2500	4.17	2.61	0.73	
3150	3.50	2.26	0.77	
4000	2.85	1.90	0.82	0.85
5000	2.25	1.51	0.97	
6300*	1.66	1.16	1.09	
8000*	1.38	0.98	1.13	n/a
10000*	0.93	0.69	1.36	

Sound Absorption Coefficient

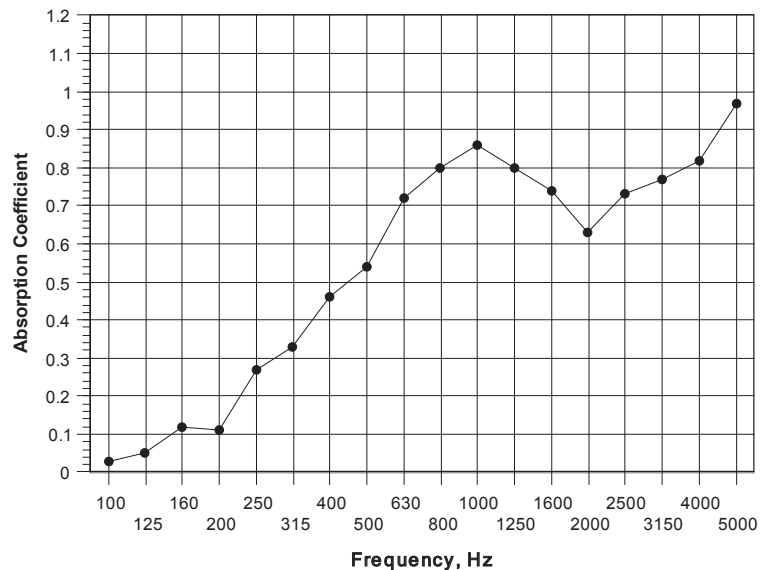

$A_w$  0.55(MH)

Class D

Calculated to EN ISO 11654:1997

NRC 0.60

Calculated to ASTM C 423-01

\* Denotes frequencies outside the range covered by BS EN ISO 354:2003

T1, empty room reverberation time

T2, room reverberation time with sample

# Practical absorption coefficient, BS EN ISO 11654:1997

v4.3

# Acoustic Test Report - Absorption

**Absorption Class:** C

Calculated to EN ISO 11654:1997

**Fabric:** Wool Serge 565

**Fullness:** Flat

**Cavity from Wall:** 350mm



Inspiration in every performance

## Data Sheet 10

The Laboratory Measurement of Random Incidence Sound Absorption generally to BS EN ISO 354:2003

**Client:** J&C Joel Ltd

**Test Date:** 12/04/2014

**Empty Room:** **Temperature:** 17.0 °C **Humidity:** 57 %RH **Pressure:** 1010 mbar

**Room with Sample:** **Temperature:** 16.7 °C **Humidity:** 50 %RH **Pressure:** 1009 mbar

**Sample Description:** Wool Serge 565 - Single Layer – Flat (Approx. weight 565g/m<sup>2</sup>) – 350mm cavity from wall

**Mounting Method:** G-350

**Sample Area:** 9 m<sup>2</sup>

**Chamber Volume:** 300 m<sup>3</sup>

### Test 11

Freq Hz	T1 sec	T2 sec	Absorp Coeff	Practical Absorp Coeff #
50*	5.07	4.92	0.03	
63*	4.60	3.97	0.19	n/a
80*	5.86	5.00	0.16	
100	6.96	5.59	0.19	
125	7.22	5.50	0.23	0.25
160	6.82	4.58	0.39	
200	6.37	4.11	0.47	
250	7.19	4.08	0.57	0.55
315	7.06	3.86	0.64	
400	6.40	3.60	0.66	
500	5.35	3.31	0.63	0.60
630	5.03	3.30	0.57	
800	5.43	3.21	0.69	
1000	5.96	3.37	0.70	0.70
1250	5.70	3.31	0.68	
1600	5.08	3.02	0.71	
2000	4.62	2.83	0.72	0.75
2500	4.17	2.57	0.76	
3150	3.50	2.23	0.80	
4000	2.85	1.85	0.90	0.90
5000	2.25	1.49	1.02	
6300*	1.66	1.16	1.09	
8000*	1.38	0.98	1.13	n/a
10000*	0.93	0.69	1.36	

Sound Absorption Coefficient

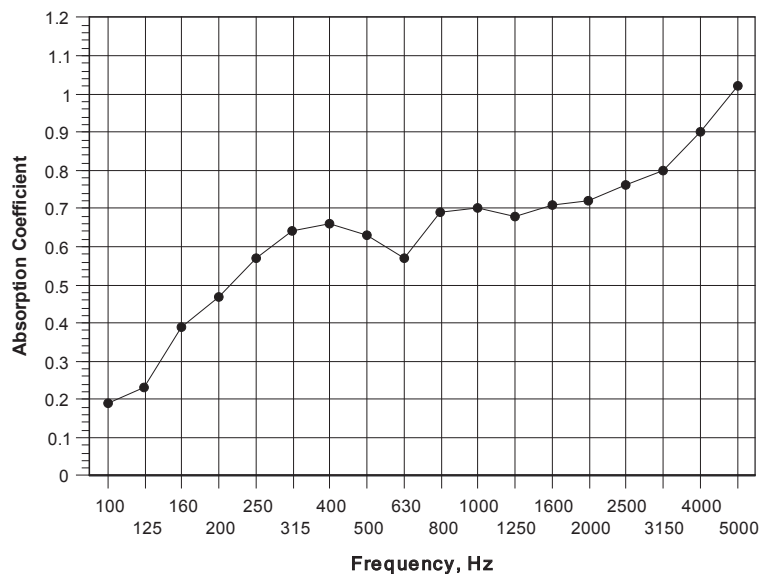

$\alpha_w$  0.70(H)

Class C

Calculated to EN ISO 11654:1997

NRC 0.65

Calculated to ASTM C 423-01

\* Denotes frequencies outside the range covered  
by BS EN ISO 354:2003

T1, empty room reverberation time  
T2, room reverberation time with sample

# Practical absorption coefficient, BS EN ISO 11654:1997

v4.3

# Acoustic Test Report - Absorption

**Absorption Class:** B

Calculated to EN ISO 11654:1997

**Fabric:** Wool Serge 565

**Fullness:** 50%

**Cavity from Wall:** 100mm



Inspiration in every performance

## Data Sheet 13

The Laboratory Measurement of Random Incidence Sound Absorption generally to BS EN ISO 354:2003

**Client:** J&C Joel Ltd

**Test Date:** 12/04/2014

**Empty Room:** Temperature: 17.0 °C Humidity: 57 %RH Pressure: 1010 mbar

**Room with Sample:** Temperature: 16.7 °C Humidity: 49 %RH Pressure: 1009 mbar

**Sample Description:** Wool Serge 565 – Single Layer – 50% fullness (Approx. weight 565g/m<sup>2</sup>) – 100mm cavity from wall

**Mounting Method:** G-100

**Sample Area:** 9 m<sup>2</sup>

**Chamber Volume:** 300 m<sup>3</sup>

### Test 14

Freq Hz	T1 sec	T2 sec	Absorp Coeff	Practical Absorp Coeff #
50*	5.07	5.19	-0.02	
63*	4.60	4.16	0.12	n/a
80*	5.86	5.26	0.10	
100	6.96	6.42	0.06	
125	7.22	5.91	0.16	0.15
160	6.82	5.07	0.27	
200	6.37	4.60	0.33	
250	7.19	4.18	0.54	0.50
315	7.06	3.96	0.60	
400	6.40	3.51	0.70	
500	5.35	2.96	0.82	0.80
630	5.03	2.67	0.95	
800	5.43	2.83	0.92	
1000	5.96	2.99	0.90	0.90
1250	5.70	2.99	0.85	
1600	5.08	2.80	0.85	
2000	4.62	2.65	0.84	0.85
2500	4.17	2.39	0.91	
3150	3.50	2.13	0.90	
4000	2.85	1.81	0.94	1.00
5000	2.25	1.45	1.09	
6300*	1.66	1.11	1.25	
8000*	1.38	0.94	1.30	n/a
10000*	0.93	0.66	1.62	

Sound Absorption Coefficient

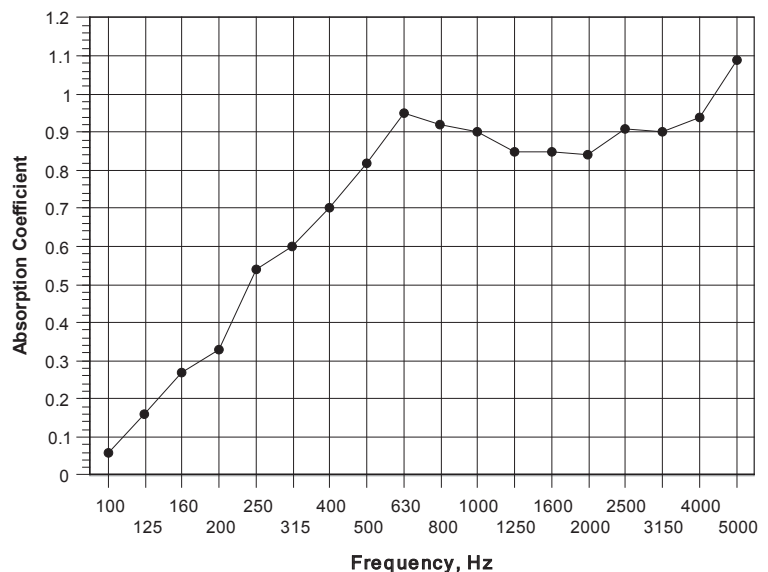

$\alpha_w$  0.80(H)

Class B

Calculated to EN ISO 11654:1997

NRC 0.80

Calculated to ASTM C 423-01

\* Denotes frequencies outside the range covered by BS EN ISO 354:2003

T1, empty room reverberation time  
T2, room reverberation time with sample

# Practical absorption coefficient, BS EN ISO 11654:1997

v4.3

# Acoustic Test Report - Absorption

**Absorption Class:** B

Calculated to EN ISO 11654:1997

**Fabric:** Wool Serge 565

**Fullness:** 50%

**Cavity from Wall:** 350mm



Inspiration in every performance

## Data Sheet 14

### The Laboratory Measurement of Random Incidence Sound Absorption generally to BS EN ISO 354:2003

**Client:** J&C Joel Ltd

**Test Date:** 12/04/2014

**Empty Room:** **Temperature:** 17.0 °C **Humidity:** 57 %RH **Pressure:** 1010 mbar

**Room with Sample:** **Temperature:** 16.1 °C **Humidity:** 49 %RH **Pressure:** 1009 mbar

**Sample Description:** Wool Serge 565 – Single Layer – 50% fullness (Approx. weight 565g/m<sup>2</sup>) – 350mm cavity from wall

**Mounting Method:** G-350

**Sample Area:** 9 m<sup>2</sup>

**Chamber Volume:** 300 m<sup>3</sup>

### Test 15

Freq Hz	T1 sec	T2 sec	Absorp Coeff	Practical Absorp Coeff #
50*	5.07	4.88	0.04	
63*	4.60	4.17	0.12	n/a
80*	5.86	4.93	0.17	
100	6.96	5.24	0.26	
125	7.22	5.11	0.31	0.35
160	6.82	4.16	0.51	
200	6.37	3.89	0.54	
250	7.19	3.64	0.73	0.70
315	7.06	3.40	0.83	
400	6.40	3.37	0.76	
500	5.35	3.15	0.71	0.75
630	5.03	2.84	0.84	
800	5.43	2.92	0.86	
1000	5.96	2.99	0.90	0.90
1250	5.70	2.93	0.89	
1600	5.08	2.76	0.88	
2000	4.62	2.61	0.87	0.90
2500	4.17	2.33	0.96	
3150	3.50	2.07	0.96	
4000	2.85	1.76	1.00	1.00
5000	2.25	1.40	1.18	
6300*	1.66	1.08	1.32	
8000*	1.38	0.94	1.21	n/a
10000*	0.93	0.66	1.50	

Sound Absorption Coefficient

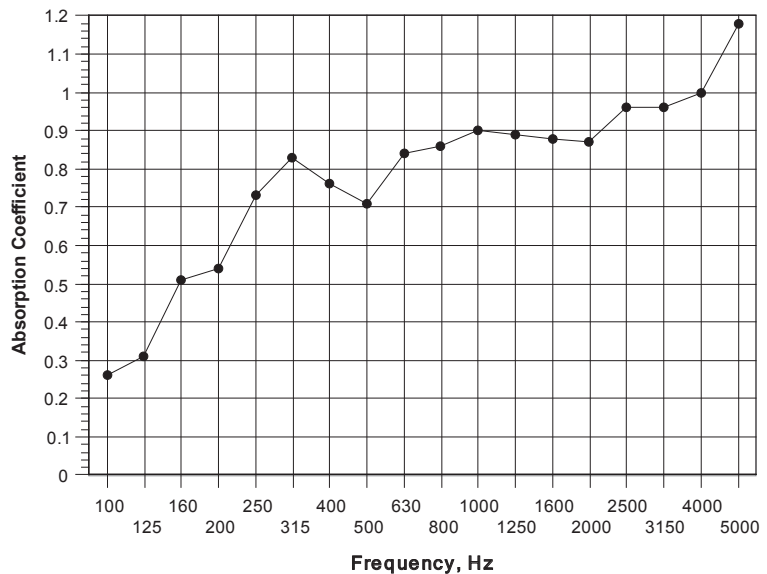

$a_w$  0.85(H)

Class B

Calculated to EN ISO 11654:1997

NRC 0.80

Calculated to ASTM C 423-01

\* Denotes frequencies outside the range covered by BS EN ISO 354:2003

T1, empty room reverberation time  
T2, room reverberation time with sample

# Practical absorption coefficient, BS EN ISO 11654:1997

v4.3

# Acoustic Test Report - Absorption

**Absorption Class:** A

Calculated to EN ISO 11654:1997

**Fabric:** Wool Serge 565

**Fullness:** 100%

**Cavity from Wall:** 100mm



Inspiration in every performance

## Data Sheet 16

The Laboratory Measurement of Random Incidence Sound Absorption generally to BS EN ISO 354:2003

**Client:** J&C Joel Ltd

**Test Date:** 12/04/2014

**Empty Room:** **Temperature:** 17.0 °C **Humidity:** 57 %RH **Pressure:** 1010 mbar

**Room with Sample:** **Temperature:** 16.7 °C **Humidity:** 49 %RH **Pressure:** 1009 mbar

**Sample Description:** Wool Serge 565 – Single Layer – 100% fullness (Approx. weight 565g/m<sup>2</sup>) – 100mm cavity from wall

**Mounting Method:** G-100

**Sample Area:** 9 m<sup>2</sup>

**Chamber Volume:** 300 m<sup>3</sup>

### Test 17

Freq Hz	T1 sec	T2 sec	Absorp Coeff	Practical Absorp Coeff #
50*	5.07	5.35	-0.06	
63*	4.60	3.67	0.30	n/a
80*	5.86	5.36	0.09	
100	6.96	6.57	0.05	
125	7.22	5.26	0.28	0.20
160	6.82	4.85	0.32	
200	6.37	4.32	0.40	
250	7.19	3.85	0.65	0.60
315	7.06	3.71	0.69	
400	6.40	3.25	0.82	
500	5.35	2.91	0.85	0.90
630	5.03	2.61	1.00	
800	5.43	2.78	0.95	
1000	5.96	2.87	0.98	0.95
1250	5.70	2.82	0.96	
1600	5.08	2.72	0.91	
2000	4.62	2.58	0.90	0.90
2500	4.17	2.34	0.96	
3150	3.50	2.09	0.95	
4000	2.85	1.75	1.04	1.00
5000	2.25	1.43	1.14	
6300*	1.66	1.11	1.25	
8000*	1.38	0.95	1.24	n/a
10000*	0.93	0.67	1.50	

Sound Absorption Coefficient

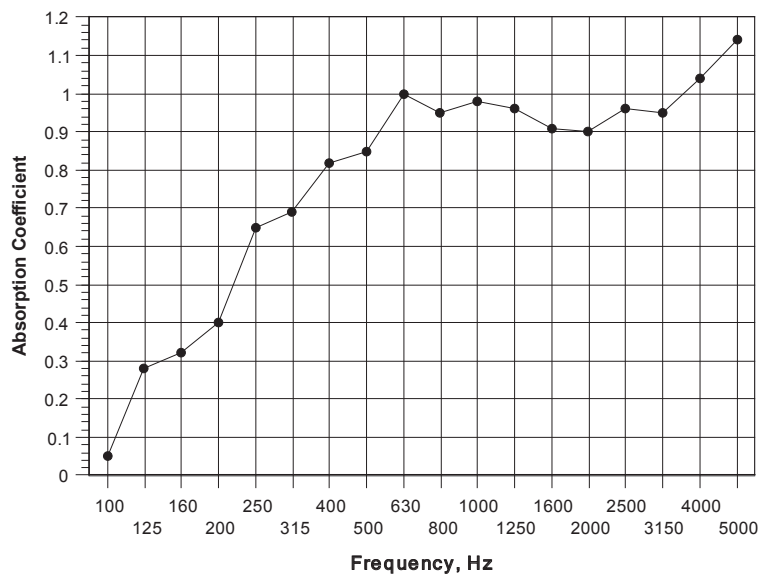

$\alpha_w$  0.90

Class A

Calculated to EN ISO 11654:1997

NRC 0.85

Calculated to ASTM C 423-01

\* Denotes frequencies outside the range covered by BS EN ISO 354:2003

T1, empty room reverberation time  
T2, room reverberation time with sample

# Practical absorption coefficient, BS EN ISO 11654:1997

v4.3

# Acoustic Test Report - Absorption

**Absorption Class:** A

Calculated to EN ISO 11654:1997

**Fabric:** Wool Serge 565

**Fullness:** 100%

**Cavity from Wall:** 350mm



Inspiration in every performance

## Data Sheet 15

### The Laboratory Measurement of Random Incidence Sound Absorption generally to BS EN ISO 354:2003

**Client:** J&C Joel Ltd

**Test Date:** 12/04/2014

**Empty Room:** **Temperature:** 17.0 °C **Humidity:** 57 %RH **Pressure:** 1010 mbar

**Room with Sample:** **Temperature:** 16.7 °C **Humidity:** 49 %RH **Pressure:** 1009 mbar

**Sample Description:** Wool Serge 565 – Single Layer – 100% fullness (Approx. weight 565g/m<sup>2</sup>) – 350mm cavity from wall

**Mounting Method:** G-350

**Sample Area:** 9 m<sup>2</sup>

**Chamber Volume:** 300 m<sup>3</sup>

### Test 16

Freq Hz	T1 sec	T2 sec	Absorp Coeff	Practical Absorp Coeff #
50*	5.07	4.93	0.03	
63*	4.60	3.72	0.28	n/a
80*	5.86	5.22	0.11	
100	6.96	5.48	0.21	
125	7.22	5.02	0.33	0.35
160	6.82	4.33	0.45	
200	6.37	3.89	0.54	
250	7.19	3.60	0.75	0.70
315	7.06	3.43	0.81	
400	6.40	3.34	0.78	
500	5.35	3.09	0.74	0.80
630	5.03	2.76	0.89	
800	5.43	2.71	1.00	
1000	5.96	2.86	0.98	1.00
1250	5.70	2.78	0.99	
1600	5.08	2.59	1.01	
2000	4.62	2.49	0.97	1.00
2500	4.17	2.28	1.02	
3150	3.50	2.00	1.07	
4000	2.85	1.68	1.17	1.00
5000	2.25	1.38	1.28	
6300*	1.66	1.08	1.39	
8000*	1.38	0.93	1.36	n/a
10000*	0.93	0.67	1.50	

Sound Absorption Coefficient

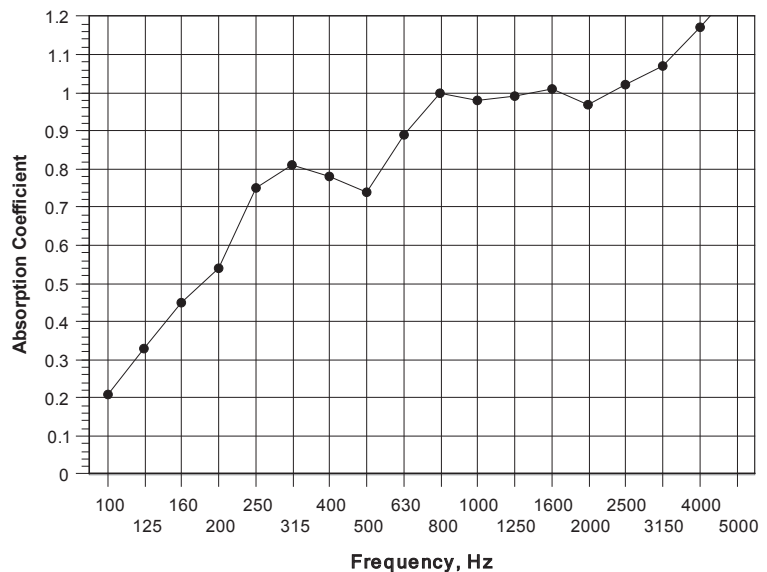

$a_{\omega}$  0.90

Class A

Calculated to EN ISO 11654:1997

NRC 0.85

Calculated to ASTM C 423-01

\* Denotes frequencies outside the range covered by BS EN ISO 354:2003

T1, empty room reverberation time  
T2, room reverberation time with sample

# J&C Joel 捷成

Inspiration in every performance



**J&C Joel United Kingdom - HQ**  
uksales@jcjoel.com



**J&C Joel Europe**  
eusales@jcjoel.com



**J&C Joel Middle East**  
uaesales@jcjoel.com



**J&C Joel Vietnam**  
asiasales@jcjoel.com



**J&C Joel Macau**  
asiasales@jcjoel.com

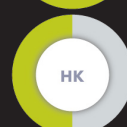

**J&C Joel Hong Kong**  
asiasales@jcjoel.com

## **8. Coloured Wool Serge Datapack**

Datapack shown overleaf.

# Coloured Wool Serge

Perfect For: Masking • Decorative/Scenic • Film & TV • Stage • Acoustics

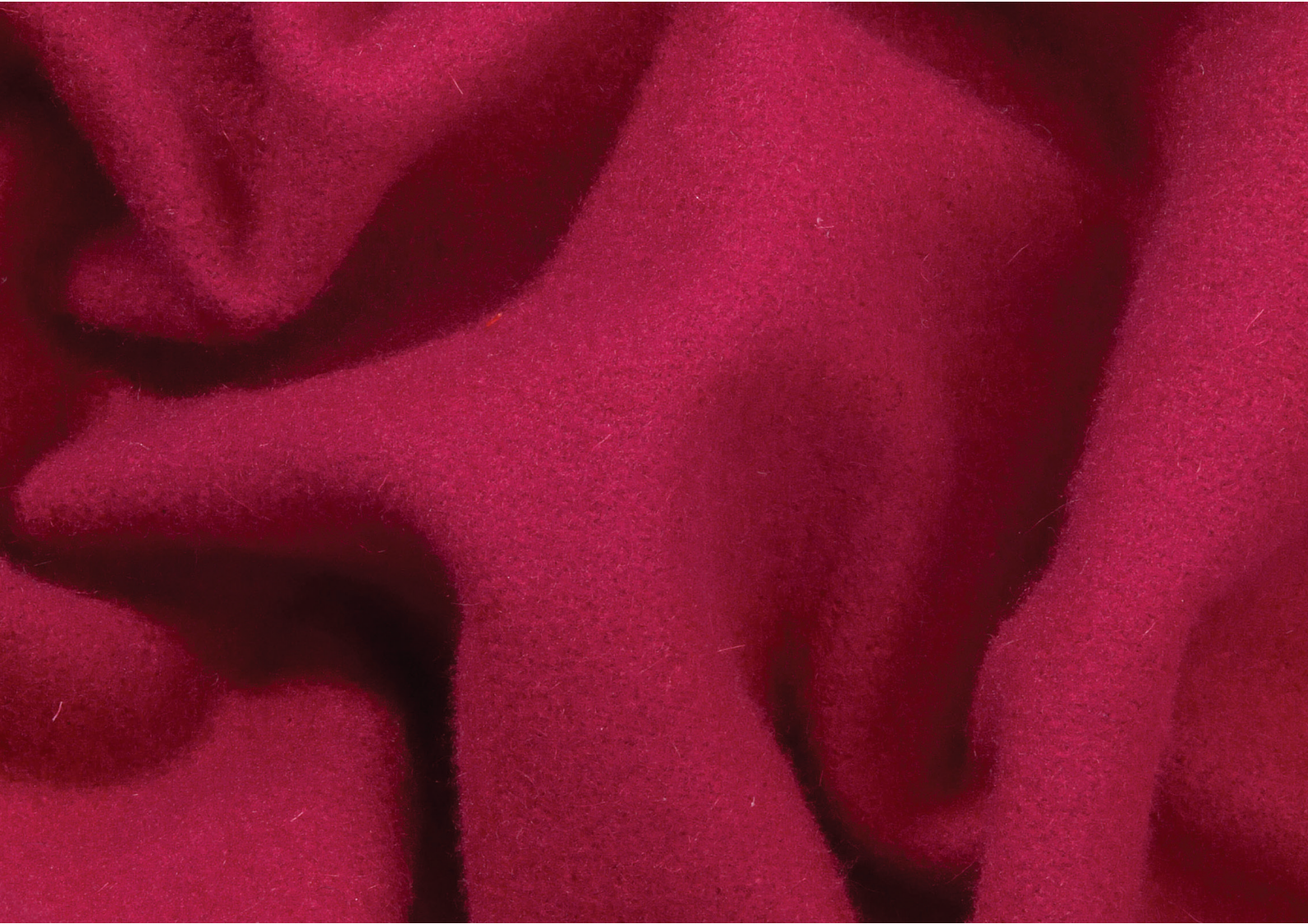

**J&C Joel** 

the inspiration behind the performance

## Composition & Care

150 cm 3

## Fire Certificate

BS5867 Part 2 Type B 4

IMO 8

## Acoustic Test Report

50% Fullness 13

100% Fullness 15

## TECHNICAL

 **NDFR**  
**Non Durably Flame Retardant**  
chemically treated with a water solution and if wetted in any way should be retreated

 **DFR**  
**Durably Flame Retardant**  
chemically treated to withstand a number of cleanings

 **IFR**  
**Inherently Flame Retardant**  
woven from fibres with a high flame retardancy

 **FR**  
**Flame Retardant**  
chemically treated to an individual specification

 **NOT FR**  
**Not Flame Retardant** no flame retardant treatment

 Confirmation that the fabric meets one or more flame retardant standards

**BS5867** BS5867 Pt2 B is the British Standard for flame retardant fabrics used for curtains and drapes

**BS5852** BS5852 Pt1 is the British Standard for flammability of upholstered composites for seating

**BS4790** BS4790: 1987 Determination of the effects of a small source of ignition on textile floor coverings hot metal nut method (method 1, loose laid)

**EN13773: 2003** Meets European fire safety standards for vertically hung fabrics. Burning behavior, ignitability testing of curtain fabric for use in the contract market.

**TL 1080-0002/8** German Military Specification for horizontally tested materials

**EN14041** Details the requirement for CE Marking of textiles, laminate and resilient floor coverings

**BS7905-1:2001** Lifting equipment for performance, broadcast and similar applications.

## ATTRIBUTES

 Approx roll length of material in linear metres (m) & feet (ft)

 Approx width of material in centimetres (cm) & inches (")

 Approx weight in grams per metre squared (g/m<sup>2</sup>)

 Approx thickness in (mm)

**M1, M2, M4** Conforms to French Fire Regulations

**B1, B2** Conforms to German Fire Regulations DIN 4102

**IMO** Conforms to International Maritime Organisation regulations

**Classe Uno** Meets Italian Fire Regulations

**BS EN13501-1** Fire Classification of construction, products and building elements. Classification using test data from reaction to fire tests

**CFC EN ISO 9239-1** Reaction to fire test. Horizontal surface spread of flame on floor covering system. Determination of the burning behaviour using a retardant heat source

**NFPA 701** NFPA 701: (USA) Standard Methods of Fire Tests for Flame Propagation of Textiles and Films





**EN9239-1** Reaction to fire tests – horizontal surface spread of flame on floor covering systems

**DIN EN1021** Meets European fire safety standards for exposure to different ignition sources, namely a lit cigarette and butane flame. Assessment of the ignitability of upholstered furniture

# Datasheet - Fabrics & Flooring

## Coloured Wool Serge

To ensure you get the best from the product supplied to you, we advise you follow the care instructions within this datasheet.

Fabric	Flame Retardancy	IFR
	Fire Certification	BS5867, IMO
	Brand Name (and Manufacturer)	J&C Joel Ltd.
	Material (Blending Ratio)	Blend of Wool (100% Wool), and Recycled Wool (95% Wool, 5% Nylon & Other Fibres)
	Construction of Fabric	Plain Weave • Yarn Count: Medium • Ends/Picks: High Density
	Method of Dying	Batch Dyed. Min 2 rolls, Max 4 rolls, per batch.
Chemicals	Brand Name of Flame Retardant Chemicals	N/A
	Chemical name of Flame Retardant Chemicals	N/A
	Process of Flame Retardant Chemicals	N/A
Care	Information	<p>Inherently Flame Retardant to BS5867 Part 2 Type B and IMO. This means that the man-made fibres are flame retardant for life and if wet, would not need to be re-flameproofed. Therefore, the cloth will withstand wet cleaning but we would advise and suggest professional dry cleaning only, using the correct chemical process.</p> <p>Notwithstanding the aforementioned, it would be our advice to only dry clean this material periodically. We would suggest that the curtain be soft-brushed on a regular basis and periodically cleaned using a vacuum and drapery attachment.</p> <p>This fabric is not pre-shrunk.</p>
	Laundering Treatment	<div style="display: flex; justify-content: space-around; align-items: center;"> <div style="text-align: center;"> Dry Clean Only</div> <div style="text-align: center;"> Do Not Wash</div> <div style="text-align: center;"> Do Not Bleach</div> <div style="text-align: center;"> Do Not Iron</div> <div style="text-align: center;"> Do Not Tumble Dry</div> </div>
Other Finishes	Pressed, Blown Finish	
Notes		

  
Fire Rating:  
IFR

  
Approx Roll Length:  
57m / 187ft

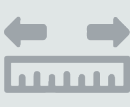
  
Width:  
150cm / 59"

  
Weight:  
500 g/m<sup>2</sup>

  
Fire Certification:  
BS5867, IMO

  
Colours Available  
17

  
Fabric Thickness:  
\*1.70mm

\*FABRIC THICKNESS Measured in-house with digital callipers, not under laboratory conditions.

For further information please contact our sales team [sales@jcjoel.com](mailto:sales@jcjoel.com)

# Fire Test Certificate – Specimen

**Fabric:** Coloured Wool Serge  
**Type:** BS5867 Part 2 Type B

# J&C Joel

the inspiration behind the performance



TESTING • CERTIFICATION • AUDITING

Wira House, West Park Ring Road,  
Leeds, LS16 6QL, UK.  
Telephone: +44 (0)113 259 1999  
Email: [info@bttg.co.uk](mailto:info@bttg.co.uk)  
Website: [www.bttg.co.uk](http://www.bttg.co.uk)

Date: 27 June 2019

**Our Ref:** 56524-1  
**Your Ref:** 57074

Page: 1 of 4

**Client:** J. & C. Joel Limited  
Corporation Mill  
Corporation Street  
Sowerby Bridge  
Halifax  
HX6 2QQ

**Job Title:** Surface Ignition Of Curtains & Drapes

**Client's Order No:** 57074

**Date of Receipt:** 18 June 2019

**Date of Test Start:** 26 June 2019

**Description of Sample(s):** One sample identified as follows was received for testing:

Coloured Wool Serge IFR, stated to be 100% wool

**Work Requested:** We were asked to make the following test:

BS 5867: Part 2: 2008 (2015): Type B Curtains, Drapes and Blinds

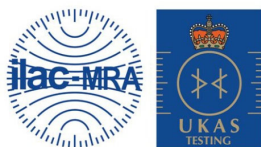

1066

Shirley® Technologies Limited. Registered Office: Wira House, West Park Ring Road, Leeds, LS16 6QL.  
A company registered in England & Wales with company number 04669651. VAT Number GB 816764800.  
The supply of all goods and services is subject to our standard terms of business, copies of which are available on request.  
Our laboratories are accredited to EN ISO/IEC 17025.

Copyright © 2019 Shirley Technologies Limited. All rights reserved.

# Fire Test Certificate – Specimen

**Fabric:** Coloured Wool Serge  
**Type:** BS5867 Part 2 Type B

# J&C Joel

the inspiration behind the performance



TESTING • CERTIFICATION • AUDITING

J. & C. Joel Limited

Sample was identified as follows:

Coloured Wool Serge IFR, stated to be 100% wool

BS 5867: Part 2: 2008 (2015): Type B Curtains, Drapes and Blinds  
Testing as received.

Three specimens from both length and width were tested in accordance with BS EN ISO 15025: Procedure A (surface ignition): 2002. The sample was tested at 21°C and 44 % relative humidity (R.H.).

Each specimen was subjected to an applied flame using butane and a 15 second flame application time. The results obtained (shown in the table below) were assessed according to the requirements of BS 5867: Part 2: 2008 (2015).

#### Pre-treatment

If the fabric is a pass in the 'as received' condition then the fabric is subjected a water soak procedure as specified in BS EN 1021: Annex D: 2006.

#### Testing after pre-treatment

Three specimens, after pre-treatment, from both length and width were tested following the procedure described above.

Test results relate only to the sample tested.

The results for all tests are given in the table(s) on the following page(s).

Reported by:   
B Bland  
Laboratory Technician

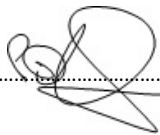
Countersigned By:   
P Doherty  
Manager

Enquiries concerning this report should be addressed to Customer Services.



1066

Shirley® Technologies Limited. Registered Office: Wira House, West Park Ring Road, Leeds, LS16 6QL.  
A company registered in England & Wales with company number 04669651. VAT Number GB 816764800.  
The supply of all goods and services is subject to our standard terms of business, copies of which are available on request.  
Our laboratories are accredited to EN ISO/IEC 17025.

Copyright © 2019 Shirley Technologies Limited. All rights reserved.

# Fire Test Certificate – Specimen

**Fabric:** Coloured Wool Serge  
**Type:** BS5867 Part 2 Type B



TESTING • CERTIFICATION • AUDITING

J. & C. Joel Limited

**RESULTS**

Sample Ref: Coloured Wool Serge IFR, stated to be 100% wool

Wira House, West Park Ring Road,  
 Leeds, LS16 6QL, UK.  
 Telephone: +44 (0)113 259 1999  
 Email: [info@bttg.co.uk](mailto:info@bttg.co.uk)  
 Website: [www.bttg.co.uk](http://www.bttg.co.uk)

Date: 27 June 2019

**Our Ref:** 56524-1  
**Your Ref:** 57074

Page: 3 of 4

BS 5867: Part 2: 2008 (2015): Type B Curtains, Drapes and Blinds  
Testing as Received

Specimen No.	Length			Width		
	1	2	3	4	5	6
Flame reached an edge	No	No	No	No	No	No
Hole reached an edge	No	No	No	No	No	No
Flaming debris separated	No	No	No	No	No	No

Requirements

Any "Yes" means fail except if only one specimen fails a further 6 specimens are tested, if the second 6 specimens all pass the result is a pass.

Result in `as received`: Pass

Testing after pre-treatment

Specimen No.	Length			Width		
	1	2	3	4	5	6
Flame reached an edge	No	No	No	No	No	No
Hole reached an edge	No	No	No	No	No	No
Flaming debris separated	No	No	No	No	No	No

Requirements

Any "Yes" means fail except if only one specimen fails a further 6 specimens are tested, if the second 6 specimens all pass the result is a pass.

Result in `after pre-treatment`: Pass

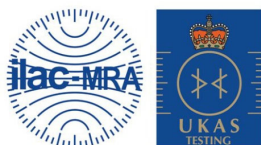

1066

Shirley® Technologies Limited. Registered Office: Wira House, West Park Ring Road, Leeds, LS16 6QL.  
 A company registered in England & Wales with company number 04669651. VAT Number GB 816764800.  
 The supply of all goods and services is subject to our standard terms of business, copies of which are available on request.  
 Our laboratories are accredited to EN ISO/IEC 17025.

Copyright © 2019 Shirley Technologies Limited. All rights reserved.

# Fire Test Certificate – Specimen

**Fabric:** Coloured Wool Serge  
**Type:** BS5867 Part 2 Type B

# J&C Joel

the inspiration behind the performance



TESTING • CERTIFICATION • AUDITING

J. & C. Joel Limited

## Conclusion

The fabric meets the Type B performance requirements of BS 5867: Part 2: 2008 (2015).

This material should be identified with the manufacturers name, trademark or other identifying mark, the statement 'Flammability complies with the requirements of BS 5867: Part 2: Type B and instructions of any special precautions to be taken concerning care (including cleansing) of the curtain, drape or window blind to be manufactured from the fabric, preferably using an appropriate care labelling symbol in accordance with BS EN 23758 and taking account of the pre-treatment using in this test and the requirements of Clause 4 of BS 5867: Part 2: 2008 (2015). If the fabric is unsuitable for cleansing, this shall be stated.

## Uncertainty Budget

There is no uncertainty budget associated with BS 5867: Part 2: Type B as no measurements are determined, the pass/fail criteria is assessed visually.

Wira House, West Park Ring Road,  
Leeds, LS16 6QL, UK.  
Telephone: +44 (0)113 259 1999  
Email: [info@bttg.co.uk](mailto:info@bttg.co.uk)  
Website: [www.bttg.co.uk](http://www.bttg.co.uk)

Date: 27 June 2019

**Our Ref:** 56524-1  
**Your Ref:** 57074

Page: 4 of 4

SPECIMEN



1066

Shirley® Technologies Limited. Registered Office: Wira House, West Park Ring Road, Leeds, LS16 6QL.  
A company registered in England & Wales with company number 04669651. VAT Number GB 816764800.  
The supply of all goods and services is subject to our standard terms of business, copies of which are available on request.  
Our laboratories are accredited to EN ISO/IEC 17025.

Copyright © 2019 Shirley Technologies Limited. All rights reserved.

# Fire Test Certificate – Specimen

**Fabric:** Coloured Wool Serge  
**Type:** IMO

# J&C Joel

the inspiration behind the performance



Wira House, West Park Ring Road, Leeds, LS16 6QL, UK.  
Telephone: +44 (0) 113 259 1999  
Email: [info@bttg.co.uk](mailto:info@bttg.co.uk)  
Website: [www.bttg.co.uk](http://www.bttg.co.uk)

Date: 16 July 2019  
Our Ref: 56603-2  
Your Ref: -  
Page: 1 of 5

Client: J. & C. Joel Limited  
Corporation Mill  
Corporation Street  
Sowerby Bridge  
Halifax  
HX6 2QQ

Job Title: Fire Test on One Sample of Fabric

Client's Order No: 57375

Date of Receipt: 7 July 2019

Description of Sample(s): One sample of fabric, referenced;  
Coloured Wool Serge IFR

Work Requested: We were asked to make the following test(s):  
IMO FTP Code 2010 Part 7

\* subcontracted test, UKAS accredited  
\*\* subcontracted test, EN ISO/IEC 17025 accredited  
\*\*\* not UKAS accredited



1066

Shirley® Technologies Limited. Registered Office: Wira House, West Park Ring Road, Leeds, LS16 6QL.  
A company registered in England & Wales with company number 04669651. VAT Number GB 816764800.  
BTTG™ and Shirley® are trade names of Shirley Technologies Limited.  
The supply of all goods and services is subject to our standard terms of business, copies of which are available on request.  
Our laboratories are accredited to EN ISO/IEC 17025.  
Copyright © 2019 Shirley Technologies Limited. All rights reserved.

# Fire Test Certificate – Specimen

**Fabric:** Coloured Wool Serge  
**Type:** IMO



TESTING • CERTIFICATION • AUDITING

Client: J. & C. Joel Limited

Wira House, West Park Ring Road, Leeds, LS16 6QL, UK.  
 Telephone: +44 (0) 113 259 1999  
 Email: [info@bttg.co.uk](mailto:info@bttg.co.uk)  
 Website: [www.bttg.co.uk](http://www.bttg.co.uk)

Date: 16 July 2019

Our Ref: 56603-2  
 Your Ref: -

Page: 2 of 5

## Product Description

Company Name	J. & C. Joel Ltd
Type of Material, i.e. Curtain, Drape, etc.	Curtain/Draperies Fabrics
Name and/or Identification of the Product Tested	Coloured Wool Serge
Mass per Unit Area (g/m <sup>2</sup> )	Approx. 500g/m <sup>2</sup>
Thickness (mm)	2mm
Colour and Tone (i)	Red/Wine
Quantity and Number of Any Coating	None
Method and Quantity of Fire Retardant Treatment	IFR
Materials of the Product and its Composite Ratio (ii)	90% wool, 10% OF
Composition of Weave (iii)	Twill
Density (Number/Inch) the Number of Threads per Inch in both warp and weft; and	Not supplied by client
Yarn Number Count	Not supplied by client

(i) If the product has a pattern, the representative colour shall be described.

(ii) Such as wool, nylon, polyester, etc.

(iii) Such as plain, weave, twilled;



1066

Shirley® Technologies Limited. Registered Office: Wira House, West Park Ring Road, Leeds, LS16 6QL.  
 A company registered in England & Wales with company number 04669651. VAT Number GB 816764800.  
 BTTG™ and Shirley® are trade names of Shirley Technologies Limited  
 The supply of all goods and services is subject to our standard terms of business, copies of which are available on request.  
 Our laboratories are accredited to EN ISO/IEC 17025.  
 Copyright © 2019 Shirley Technologies Limited. All rights reserved.

# Fire Test Certificate – Specimen

**Fabric:** Coloured Wool Serge  
**Type:** IMO

**J&C Joel**   
the inspiration behind the performance



TESTING • CERTIFICATION • AUDITING

Client: J. & C. Joel Limited

Wira House, West Park Ring Road, Leeds, LS16 6QL, UK.  
Telephone: +44 (0) 113 259 1999  
Email: [info@bttg.co.uk](mailto:info@bttg.co.uk)  
Website: [www.bttg.co.uk](http://www.bttg.co.uk)

Date: 16 July 2019

Our Ref: 56603-2  
Your Ref: -

Page: 3 of 5

## FIRE TESTS ACCORDING to IMO FTP Code 2010:Part 7 Test for Vertically Supported Textiles and Films

### Cleaning Procedure

The sample received no pre-treatment as the fabric is stated to be inherently flame retardant.

### Conditioning

The sample was conditioned for 72 hours in the standard atmosphere for conditioning textiles of  $20 \pm 5^\circ\text{C}$  and  $65 \pm 5\%$  R.H.

### Procedure

The sample was tested in accordance with IMO FTP Code 2010:Part 7. The sponsor sampled the material and the specimens were cut from the sample received to the dimensions set out in the standard.

A 40mm high propane gas flame was applied to the edge of 5 warp and 5 weft specimens for 5 seconds.

The after-flame time, length of char, existence of surface flashing and ignition of cotton waste from drops were recorded.

### Requirements

The Performance Criteria for Curtains and Drapes states that: Products which show any of the following characteristics obtained by the fire test in appendix 1, shall be considered unsuitable for use as curtains, drapes or free-hanging fabric product for use in rooms containing furniture and furnishings of restricted fire risk as defined in the relevant regulations of chapter II-2 of the Convention:-.

1. An after-flame time greater than 5 sec for any of the 10 or more specimens tested with surface application of the pilot flame.
2. Burn through to any edge of any of the 10 or more specimens tested with surface application of the pilot flame.
3. Ignition of cotton wool below specimen in any of the 10 or more specimens tested.
4. An average char length in excess of 150mm observed in any of the 10 or more specimens tested by either surface or edge ignition; and
5. The occurrence of a surface flash propagating more than 100mm from the point of ignition with or without charring of the base fabric.

If it is found that either or both of the batches of five specimens cut in both warp and weft directions fail to meet one or more of the criteria specified in subparagraphs .1 to .3 and .5 above because of poor performance of only one of the five specimens tested, one complete retest of a similar batch is permitted. Failure of the second batch to meet any of the criteria shall provide the basis for rejection of the fabric for use.



1066

Shirley® Technologies Limited. Registered Office: Wira House, West Park Ring Road, Leeds, LS16 6QL.  
A company registered in England & Wales with company number 04669651. VAT Number GB 816764800.  
BTTG™ and Shirley® are trade names of Shirley Technologies Limited  
The supply of all goods and services is subject to our standard terms of business, copies of which are available on request.  
Our laboratories are accredited to EN ISO/IEC 17025.  
Copyright © 2019 Shirley Technologies Limited. All rights reserved.

# Fire Test Certificate – Specimen

**Fabric:** Coloured Wool Serge  
**Type:** IMO



TESTING • CERTIFICATION • AUDITING

Client: J. & C. Joel Limited

Wira House, West Park Ring Road, Leeds, LS16 6QL, UK.  
 Telephone: +44 (0) 113 259 1999  
 Email: [info@bttg.co.uk](mailto:info@bttg.co.uk)  
 Website: [www.bttg.co.uk](http://www.bttg.co.uk)

Date: 16 July 2019

Our Ref: 56603-2  
 Your Ref: -

Page: 4 of 5

**As Received**

	After flame time (s)		Char length (mm)		Flaming to edge (yes or No)		Ignition of Cotton Wool from Flaming Drops (Yes or No)		Surface Flashing (Yes or No), if yes, Propagation Length (mm)	
	Warp	Weft	Warp	Warp	Weft	Weft	Warp	Weft	Warp	Weft
	3	1	4	4	No	No	No	No	No	No
	4	2	9	6	No	No	No	No	No	No
	2	7	8	39	No	No	No	No	No	No
	3	4	12	16	No	No	No	No	No	No
	3	6	11	26	No	No	No	No	No	No
Mean	3	4	9	18						

**Comment**

The results indicate the sample meets the requirements according to IMO 2010 FTP Code, Part 7.

This report relates only to the samples submitted and as described in the report.

Uncertainty of measurement has not been taken into account when presenting the test result. The relevant uncertainty value is included as an annex which forms an integral part of the report.

Reported by:   
 B Bland  
 Laboratory Technician

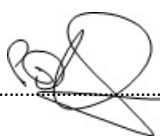
Countersigned By:   
 P Doherty  
 Manager



1066

Shirley® Technologies Limited. Registered Office: Wira House, West Park Ring Road, Leeds, LS16 6QL.  
 A company registered in England & Wales with company number 04669651. VAT Number GB 816764800.  
 BTTG™ and Shirley® are trade names of Shirley Technologies Limited  
 The supply of all goods and services is subject to our standard terms of business, copies of which are available on request.  
 Our laboratories are accredited to EN ISO/IEC 17025.  
 Copyright © 2019 Shirley Technologies Limited. All rights reserved.

# Fire Test Certificate – Specimen

**Fabric:** Coloured Wool Serge  
**Type:** IMO

# J&C Joel

the inspiration behind the performance



TESTING • CERTIFICATION • AUDITING

Client: J. & C. Joel Limited

Wira House, West Park Ring Road, Leeds, LS16 6QL, UK.

Telephone: +44 (0) 113 259 1999

Email: [info@bttg.co.uk](mailto:info@bttg.co.uk)

Website: [www.bttg.co.uk](http://www.bttg.co.uk)

Date: 16 July 2019

Our Ref: 56603-2

Your Ref: -

Page: 5 of 5

## Uncertainty Budget - Annex

The overall uncertainty budget IMO FTP Code 2010:Part 7 is as follows:-

Measurements:  $\pm 1\text{mm}$   
Duration of Flaming:  $\pm 0.5$  seconds

SPECIMEN



1066

Shirley® Technologies Limited. Registered Office: Wira House, West Park Ring Road, Leeds, LS16 6QL.  
A company registered in England & Wales with company number 04669651. VAT Number GB 816764800.  
BTTG™ and Shirley® are trade names of Shirley Technologies Limited  
The supply of all goods and services is subject to our standard terms of business, copies of which are available on request.  
Our laboratories are accredited to EN ISO/IEC 17025.  
Copyright © 2019 Shirley Technologies Limited. All rights reserved.

# Acoustic Test Report - Absorption

**Absorption Class:** B

Calculated to EN ISO 11654:1997

**Fabric:** Coloured Wool Serge

**Fullness:** 50%

**Cavity from Wall:** 100mm



the inspiration behind the performance

## Data Sheet 17

The Laboratory Measurement of Random Incidence Sound Absorption generally to BS EN ISO 354:2003

**Client:** J & C Joel Ltd

**Test Date:** 30/11/2020

**Empty Room:** **Temperature:** 16.4 °C **Humidity:** 57 %RH **Pressure:** 1016 mbar

**Room with Sample:** **Temperature:** 15.7 °C **Humidity:** 56 %RH **Pressure:** 1010 mbar

**Sample Description:** Coloured Wool Serge - Single Layer - 50% Fullness (Approx. Weight 500g/m<sup>2</sup>) - 100mm Cavity From Wall

**Mounting Method:** G - 100

**Sample Area:** 9 m<sup>2</sup>

**Chamber Volume:** 300 m<sup>3</sup>

### Test 17

Freq Hz	T1 sec	T2 sec	Absorp Coeff α <sub>s</sub>	Practical Absorp Coeff #
50*	5.15	5.21	-0.01	
63*	4.83	5.31	-0.10	n/a
80*	7.33	7.00	0.04	
100	7.42	6.33	0.13	
125	7.17	5.52	0.23	0.20
160	6.75	4.96	0.29	
200	6.77	4.62	0.37	
250	6.80	4.23	0.49	0.50
315	6.65	3.66	0.67	
400	6.46	3.23	0.84	
500	5.63	2.87	0.93	0.95
630	5.00	2.58	1.02	
800	5.22	2.72	0.96	
1000	5.79	2.93	0.92	0.95
1250	5.75	2.94	0.90	
1600	5.33	2.87	0.87	
2000	4.93	2.72	0.89	0.90
2500	4.35	2.50	0.91	
3150	3.55	2.17	0.95	
4000	2.92	1.86	1.02	1.00
5000	2.34	1.60	1.00	
6300*	1.60	1.17	1.14	
8000*	1.30	1.01	1.04	n/a
10000*	0.93	0.74	1.28	

### Sound Absorption Coefficient

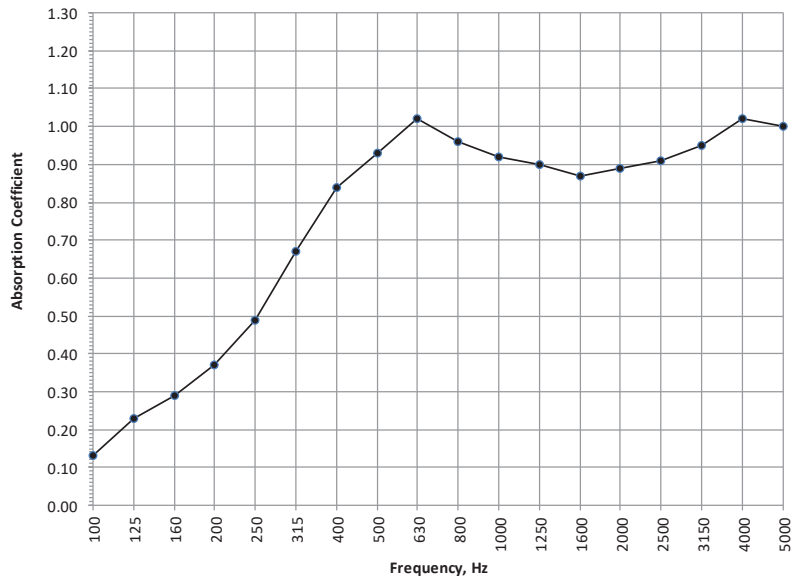

$\alpha_w$  0.80(H)

Class B

Calculated to EN ISO 11654:1997

NRC 0.80

Calculated to ASTM C 423-01

\* Denotes frequencies outside the range covered by BS EN ISO 354:2003

T1, empty room reverberation time  
T2, room reverberation time with sample

# Practical absorption coefficient, BS EN ISO 11654:1997

v5

# Acoustic Test Report - Absorption

**Absorption Class:** B

Calculated to EN ISO 11654:1997

**Fabric:** Coloured Wool Serge

**Fullness:** 50%

**Cavity from Wall:** 350mm



the inspiration behind the performance

## Data Sheet 18

The Laboratory Measurement of Random Incidence Sound Absorption generally to BS EN ISO 354:2003

**Client:** J & C Joel Ltd

**Test Date:** 30/11/2020

**Empty Room:** Temperature: 16.4 °C Humidity: 57 %RH Pressure: 1016 mbar

**Room with Sample:** Temperature: 15.7 °C Humidity: 56 %RH Pressure: 1009 mbar

**Sample Description:** Coloured Wool Serge - Single Layer - 50% Fullness (Approx. Weight 500g/m<sup>2</sup>) - 350mm Cavity From Wall

**Mounting Method:** G - 350

**Sample Area:** 9 m<sup>2</sup>

**Chamber Volume:** 300 m<sup>3</sup>

### Test 18

Freq Hz	T1 sec	T2 sec	Absorp Coeff α <sub>s</sub>	Practical Absorp Coeff #
50*	5.15	4.78	0.08	
63*	4.83	4.91	-0.02	n/a
80*	7.33	6.13	0.15	
100	7.42	5.95	0.18	
125	7.17	4.91	0.35	0.30
160	6.75	4.40	0.43	
200	6.77	4.32	0.45	
250	6.80	3.83	0.62	0.60
315	6.65	3.52	0.73	
400	6.46	3.25	0.83	
500	5.63	3.10	0.79	0.80
630	5.00	2.83	0.83	
800	5.22	2.83	0.88	
1000	5.79	2.95	0.90	0.90
1250	5.75	2.90	0.93	
1600	5.33	2.73	0.97	
2000	4.93	2.66	0.93	0.95
2500	4.35	2.41	0.99	
3150	3.55	2.12	1.01	
4000	2.92	1.81	1.10	1.00
5000	2.34	1.54	1.14	
6300*	1.60	1.14	1.26	
8000*	1.30	0.98	1.21	n/a
10000*	0.93	0.72	1.49	

### Sound Absorption Coefficient

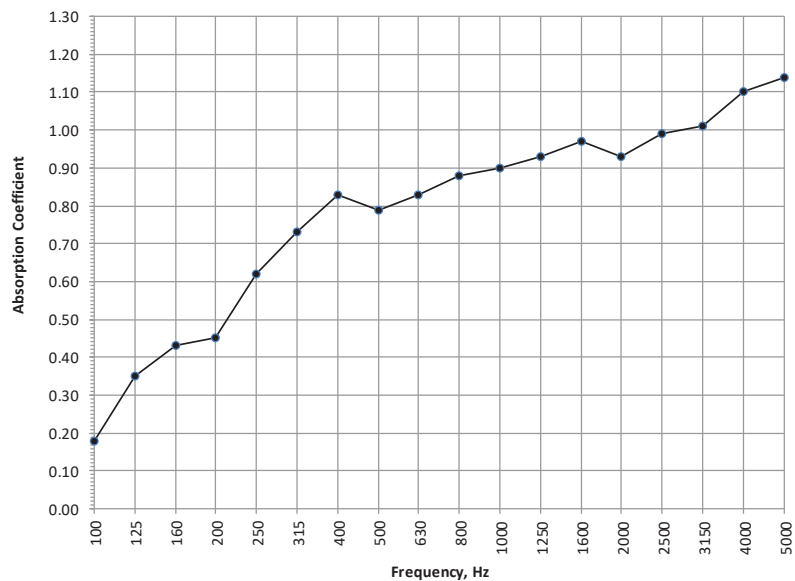

$\alpha_w$  0.85(H)

Class B

Calculated to EN ISO 11654:1997

NRC 0.80

Calculated to ASTM C423-01

\* Denotes frequencies outside the range covered

by BS EN ISO 354:2003

T1, empty room reverberation time

T2, room reverberation time with sample

# Practical absorption coefficient, BS EN ISO 11654:1997

v5

# Acoustic Test Report - Absorption

**Absorption Class:** A

Calculated to EN ISO 11654:1997

**Fabric:** Coloured Wool Serge

**Fullness:** 100%

**Cavity from Wall:** 100mm



the inspiration behind the performance

## Data Sheet 15

The Laboratory Measurement of Random Incidence Sound Absorption generally to BS EN ISO 354:2003

**Client:** J & C Joel Ltd

**Test Date:** 30/11/2020

**Empty Room:** **Temperature:** 16.4 °C **Humidity:** 57 %RH **Pressure:** 1016 mbar

**Room with Sample:** **Temperature:** 15.7 °C **Humidity:** 56 %RH **Pressure:** 1011 mbar

**Sample Description:** Coloured Wool Serge - Single Layer - 100% Fullness (Approx. Weight 500g/m<sup>2</sup>) - 100mm Cavity From Wall

**Mounting Method:** G - 100

**Sample Area:** 9 m<sup>2</sup>

**Chamber Volume:** 300 m<sup>3</sup>

### Test 15

Freq Hz	T1 sec	T2 sec	Absorp Coeff $\alpha_s$	Practical Absorp Coeff #
50*	5.15	5.05	0.02	
63*	4.83	5.12	-0.06	n/a
80*	7.33	6.97	0.04	
100	7.42	6.36	0.12	
125	7.17	5.03	0.32	0.25
160	6.75	4.74	0.34	
200	6.77	4.35	0.45	
250	6.80	3.81	0.63	0.60
315	6.65	3.44	0.76	
400	6.46	3.07	0.93	
500	5.63	2.83	0.96	0.95
630	5.00	2.57	1.03	
800	5.22	2.68	0.99	
1000	5.79	2.92	0.92	0.95
1250	5.75	2.84	0.97	
1600	5.33	2.70	0.99	
2000	4.93	2.56	1.01	1.00
2500	4.35	2.42	0.98	
3150	3.55	2.11	1.02	
4000	2.92	1.83	1.06	1.00
5000	2.34	1.55	1.11	
6300*	1.60	1.17	1.14	
8000*	1.30	0.99	1.15	n/a
10000*	0.93	0.75	1.19	

### Sound Absorption Coefficient

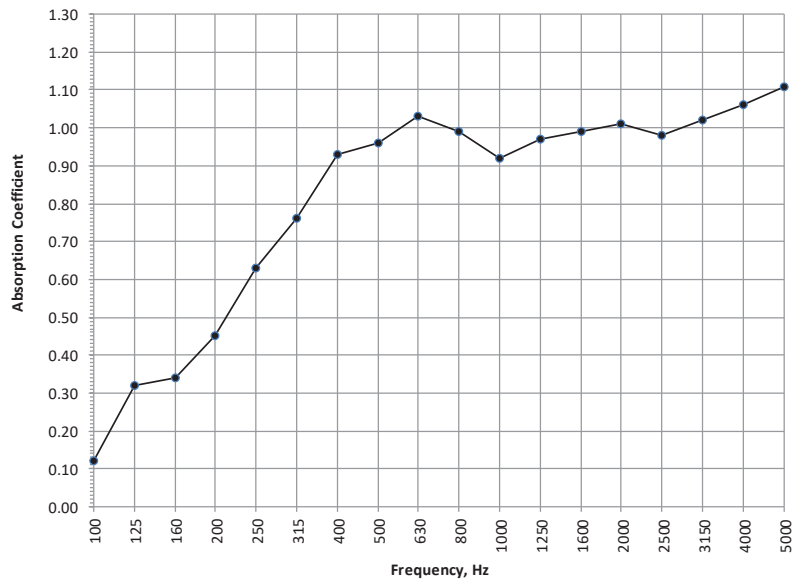

$\alpha_w$  0.90

Class A

Calculated to EN ISO 11654:1997

NRC 0.90

Calculated to ASTM C423-01

\* Denotes frequencies outside the range covered  
by BS EN ISO 354:2003

T1, empty room reverberation time  
T2, room reverberation time with sample

# Practical absorption coefficient, BS EN ISO 11654:1997

v5

# Acoustic Test Report - Absorption

**Absorption Class:** A

Calculated to EN ISO 11654:1997

**Fabric:** Coloured Wool Serge

**Fullness:** 100%

**Cavity from Wall:** 350mm



the inspiration behind the performance

## Data Sheet 16

The Laboratory Measurement of Random Incidence Sound Absorption generally to BS EN ISO 354:2003

**Client:** J & C Joel Ltd

**Test Date:** 30/11/2020

**Empty Room:** **Temperature:** 16.4 °C **Humidity:** 57 %RH **Pressure:** 1016 mbar

**Room with Sample:** **Temperature:** 15.7 °C **Humidity:** 56 %RH **Pressure:** 1010 mbar

**Sample Description:** Coloured Wool Serge - Single Layer - 100% Fullness (Approx. Weight 500g/m<sup>2</sup>) - 350mm Cavity From Wall

**Mounting Method:** G - 350

**Sample Area:** 9 m<sup>2</sup>

**Chamber Volume:** 300 m<sup>3</sup>

### Test 16

Freq Hz	T1 sec	T2 sec	Absorp Coeff $\alpha_s$	Practical Absorp Coeff #
50*	5.15	4.91	0.05	
63*	4.83	4.95	-0.03	n/a
80*	7.33	6.01	0.16	
100	7.42	5.88	0.19	
125	7.17	4.69	0.40	0.35
160	6.75	4.42	0.42	
200	6.77	4.01	0.55	
250	6.80	3.80	0.63	0.65
315	6.65	3.42	0.77	
400	6.46	3.25	0.83	
500	5.63	3.02	0.83	0.90
630	5.00	2.63	0.98	
800	5.22	2.72	0.96	
1000	5.79	2.87	0.95	1.00
1250	5.75	2.72	1.05	
1600	5.33	2.65	1.03	
2000	4.93	2.55	1.02	1.00
2500	4.35	2.32	1.08	
3150	3.55	2.01	1.15	
4000	2.92	1.73	1.24	1.00
5000	2.34	1.50	1.23	
6300*	1.60	1.14	1.26	
8000*	1.30	0.95	1.38	n/a
10000*	0.93	0.72	1.49	

### Sound Absorption Coefficient

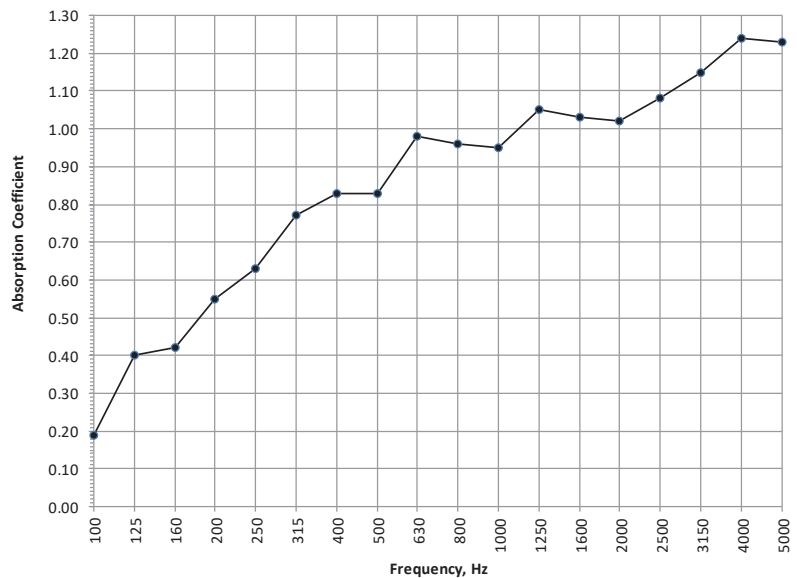

$\alpha_w$  0.90

Class A

Calculated to EN ISO 11654:1997

NRC 0.85

Calculated to ASTM C 423-01

\* Denotes frequencies outside the range covered by BS EN ISO 354:2003

T1, empty room reverberation time  
T2, room reverberation time with sample

# Practical absorption coefficient, BS EN ISO 11654:1997

v5

# J&C Joel

the inspiration behind the performance



**J&C Joel United Kingdom - HQ**  
uksales@jcjoel.com



**J&C Joel Europe**  
eusales@jcjoel.com



**J&C Joel Middle East**  
uaesales@jcjoel.com



**J&C Joel Vietnam**  
asiasales@jcjoel.com



**J&C Joel Macau**  
asiasales@jcjoel.com



**J&C Joel Hong Kong**  
asiasales@jcjoel.com