

UniTrack 0.25 m Straight Track



Technical Details

Part No: TRA0101

Weight: 0.806 kg

WLL: See Triple E WLL Sheet

Material: Welded Steel

Finish: Black Powder Coated

UniTrack is for temporary and permanent installations of heavy duty curtains and scenery with a wide range of motors and cording methods.

The TRA0101 0.25 m long (10") UniTrack section is a fabricated steel 'I' beam creating solid running surfaces and a mounting platform for a variety of accessories to fulfil movement tasks. UniTrack sections are joined together with TRA0501 joint sets.

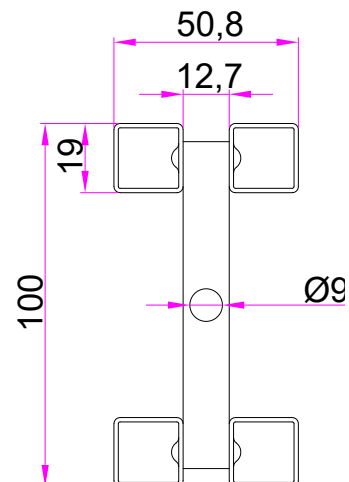

+44 (0) 1959 570 333
www.triplee.ltd
info@triplee.ltd
[@tripleeltd](https://www.instagram.com/tripleeltd)

Equipment **E**ngineered for **E**ntertainment



UniTrack 0.50 m Straight Track

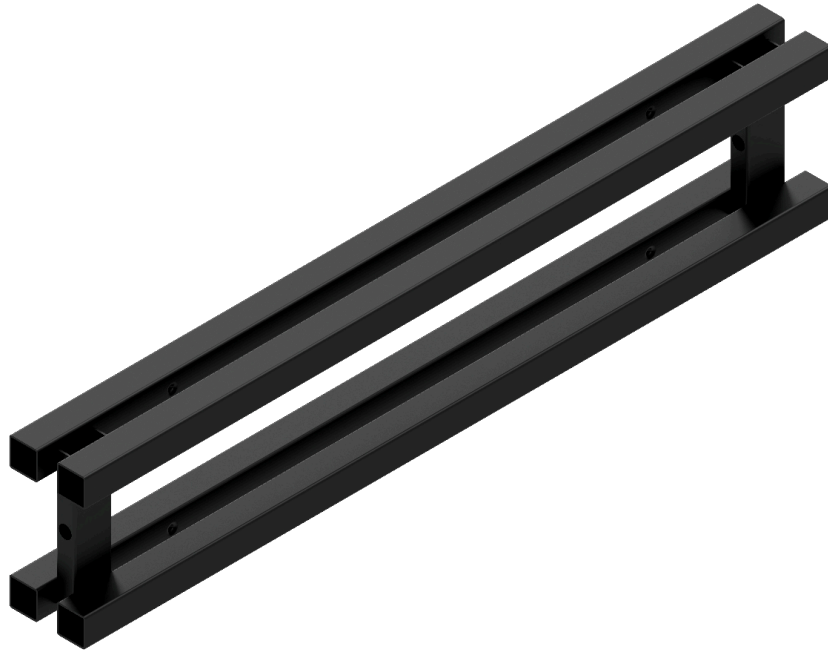

Technical Details

Part No: TRA0102

Weight: 1.466 kg

WLL: See Triple E WLL Sheet

Material: Welded Steel

Finish: Black Powder Coated

UniTrack is for temporary and permanent installations of heavy duty curtains and scenery with a wide range of motors and cording methods.

The TRA0102 0.50 m long (1'8") UniTrack section is a fabricated steel 'I' beam creating solid running surfaces and a mounting platform for a variety of accessories to fulfil movement tasks. UniTrack sections are joined together with TRA0501 joint sets.

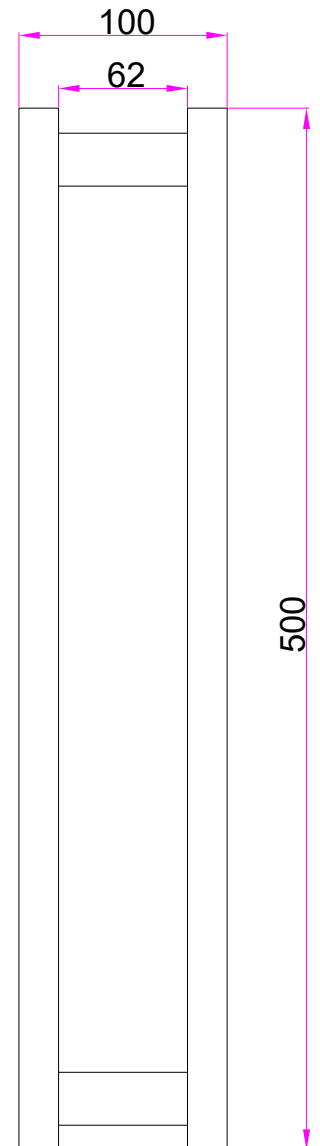
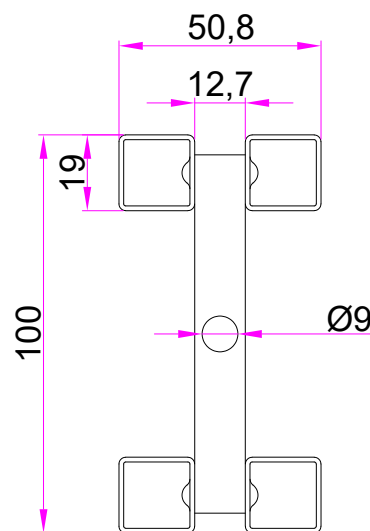

UniTrack 1.00 m Straight Track



Technical Details

Part No: TRA0103

Weight: 2.864 kg

WLL: See Triple E WLL Sheet

Material: Welded Steel

Finish: Black Powder Coated

UniTrack is for temporary and permanent installations of heavy duty curtains and scenery with a wide range of motors and cording methods.

The TRA0103 1.00 m long (3'3") UniTrack section is a fabricated steel 'I' beam creating solid running surfaces and a mounting platform for a variety of accessories to fulfil movement tasks. UniTrack sections are joined together with TRA0501 joint sets.

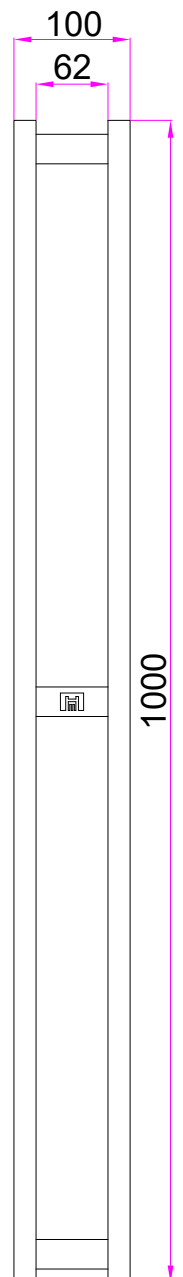
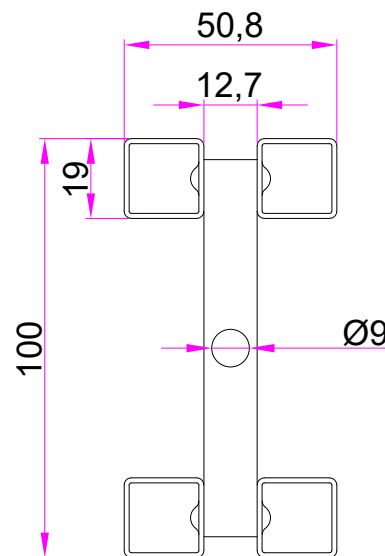

+44 (0) 1959 570 333
www.triplee.ltd
info@triplee.ltd
[@tripleeltd](https://www.instagram.com/tripleeltd)

Equipment **E**ngineered for **E**ntertainment



UniTrack 2.00 m Straight Track



Technical Details

Part No: TRA0104

Weight: 5.434 kg

WLL: See Triple E WLL Sheet

Material: Welded Steel

Finish: Black Powder Coated

UniTrack is for temporary and permanent installations of heavy duty curtains and scenery with a wide range of motors and cording methods.

The TRA0104 2.00 m long (6'6") UniTrack section is a fabricated steel 'I' beam creating solid running surfaces and a mounting platform for a variety of accessories to fulfil movement tasks. UniTrack sections are joined together with TRA0501 joint sets.

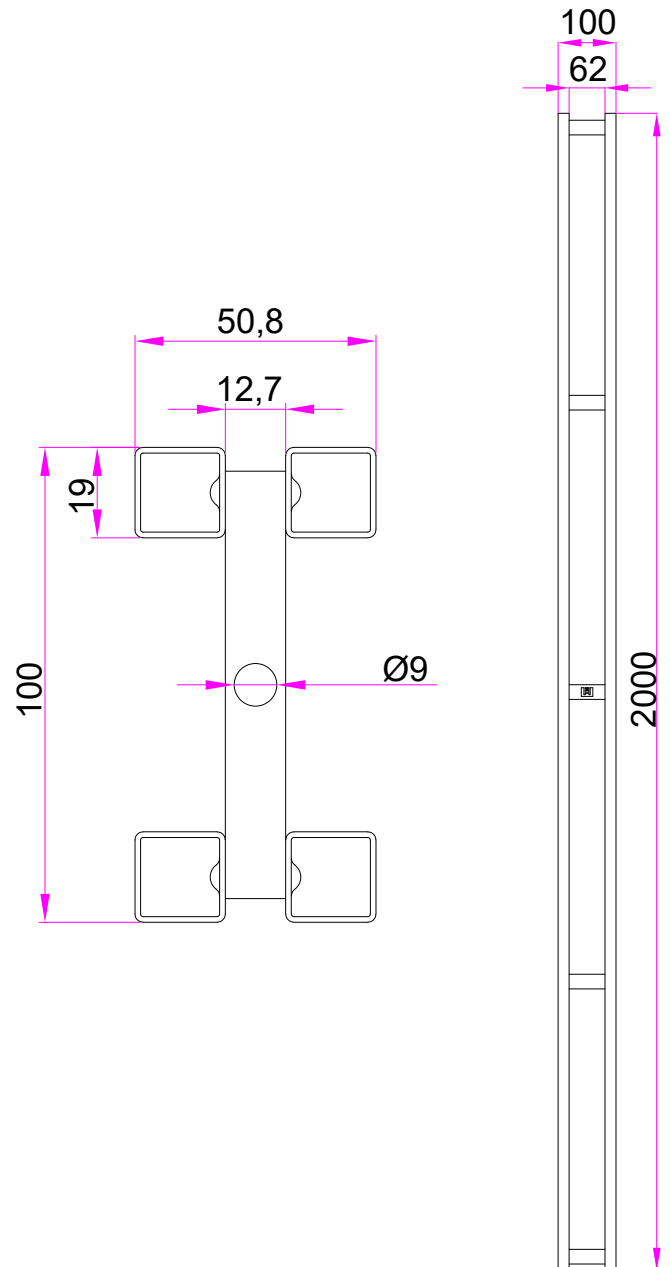

+44 (0) 1959 570 333
www.triplee.ltd
info@triplee.ltd
[@tripleeltd](https://www.instagram.com/tripleeltd)

Equipment **E**ngineered for **E**ntertainment

